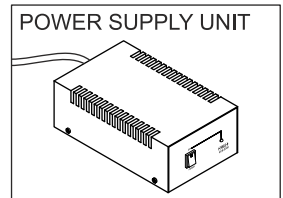
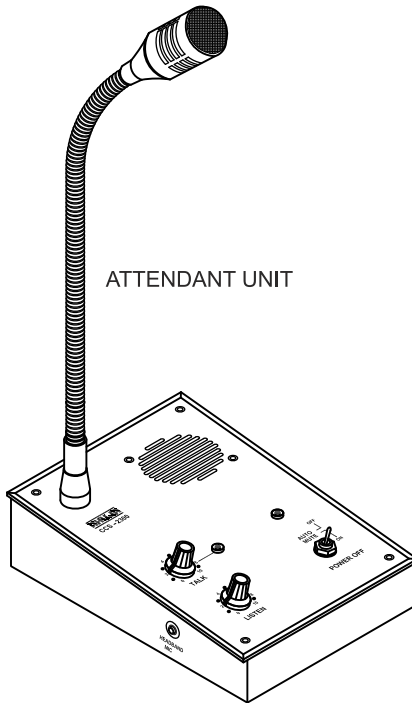

CCS-2300

- ◆ Thank you for purchasing the AHUJA Counter Communication System.
- ◆ Please read this manual thoroughly before making connections and turning on the power. Following the instructions in this manual will enable you to obtain optimum performance from your new AHUJA Counter Communication System.
- ◆ Please retain this manual for future reference.

• Safety Instructions

Read the Instructions: Please read all the instructions in this section carefully before installation or use of the product. All the safety instructions must be followed.

Retain the Instructions: Please retain this Instruction Manual for future reference.



This symbol, wherever it appears, alerts you to the presence of uninsulated hazardous voltage that may be sufficient to constitute a risk of electric shock. External wiring to any terminal marked with this symbol must be done by a trained and instructed person only.



This symbol, wherever it appears adjacent to a component, alerts you that the concerned component can only be replaced by another of the exact same specifications.

WARNING

- To reduce the risk of electric shock, do not remove the top cover. No user serviceable parts inside. Refer all servicing to qualified personnel only.
- Before replacing any fuse, make sure the set is switched off and disconnected from the AC mains or any other power source. Replace a fuse only with another of exactly same specification.

CAUTIONS

Water & Moisture: To reduce the risk of fire or electrical shock, do not expose this set to rain or moisture. Do not use this set near water or in a wet location. Do not keep any object filled with liquid, such as a vase, on top of this set. Do not insert or remove the AC mains plug with wet hands.

Power Source: The voltage & frequency of the AC mains supply, and the voltage of the external battery, (if applicable) to which this set can be connected, is marked on the rear panel of the set. Do not connect this set to any power source other than those specified on the rear panel.

Power Cord Protection: Do not cut, kink, damage or modify the AC power cord supplied with this set. Keep the AC power cord away from heaters and harmful chemicals. Do not keep any heavy object on the power cord.

Operation on Generator: When operating this set on a generator, make sure the set is switched off till the generator voltage has stabilized.

Stability: The Attendant Unit must be kept in a stable and flat horizontal position, and never in a tilted position. Do not keep the Attendant Unit on an unstable base. The customer unit must be attached securely to the glass or other partition. User must check the safe and secure mounting of the customer unit.

Earthing: This set must be earthed properly before use. A wire from the Earth terminal on the rear panel must be connected to electrical earth.

Cleaning: Disconnect this equipment from the AC mains and external battery before cleaning. Clean with a damp cloth, but do not allow any liquid to enter the set. Do not clean with liquids or aerosols.

Exposure to Heat: Do not touch the heatsinks while the set is working.

• Table of Contents

Contents	Page No.
• General Description of Product	4
• Controls & Features	5
• Installation Procedure	7
• Operating Procedure	10
• Description of Special Features	11
• Specifications	11

• General Description of Product

- Unique design, pleasing aesthetics & rugged construction.
- Facilitates two-way, hands-free communication across a counter with transparent security barrier.
- Compact & elegant Attendant Unit with 20" long gooseneck microphone, in silver coloured finish, using a unidirectional condenser cartridge.
- TALK & LISTEN volume controls on the Attendant Unit (for adjusting voice levels for the customer and the attendant respectively).
- Voice operated attendant's microphone activates only when the attendant comes forward to talk into it. The activation status is indicated by the green TALK LED.
- 3-Position toggle switch for selecting POWER OFF/AUTO MUTE ON/AUTO MUTE OFF mode of operation.
- In the Attendant Unit, red LED glows to indicate that the system is ON. The red LED glows in both AUTO MUTE ON and OFF positions.
- Exclusively designed round shaped Customer Unit, in silver coloured finish, is easy to mount on any flat surface.
- Customer unit houses an omnidirectional condenser cartridge and an efficient speaker for clear and intelligible sound.
- Attendant microphone has built-in voice priority over the customer's microphone. Customer's microphone is automatically switched off while the attendant is speaking into his microphone (green LED ON).
- Audio output for recording available through 3.5mm phone jack on the Attendant Unit.
- The system is easy to install and simple to operate.
- The Attendant unit is a table top unit which operates on 12V DC, through an AC mains operated power supply unit which is supplied alongwith.

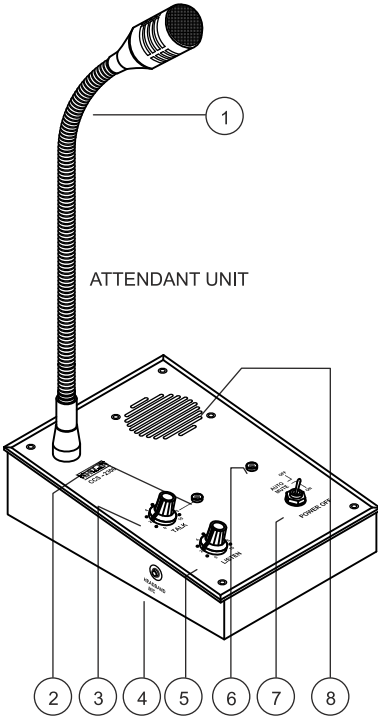

1. Microphone for attendant
20" long gooseneck microphone with a sensitive unidirectional condenser cartridge.

2. TALK LED
This green LED lights up to indicate that the Attendant Microphone is active. Attendant should talk with mouth close to the microphone. Lighting up of the green LED indicates that attendant's voice is being adequately picked up by the microphone.

The customer unit mic is automatically switched OFF when the attendant mic is being used, and green LED is glowing.

3. TALK Volume Control:
The attendant unit mic is a voice

operated mic (VOX), which is automatically switched ON by attendant's voice. The TALK control adjust the VOX sensitivity, and level of the attendant's voice through the speaker in the customer unit.

4. Socket for Headband Mic
This 3.5mm jack socket is provided for connecting Ahuja Headband mic model HBM-50. When headband mic is connected, only the goose neck mic is disabled. All other features & function, perform as usual.

5. LISTEN Volume Control
For adjusting the desired output level through the speaker in the attendant's unit.

6. POWER LED
This red LED glows to indicate that the system power is ON. This LED remains ON in Position 2 & Position 3 of the 3-way toggle switch.

7. 3-Way Toggle Switch

Position 1: The power supply to the unit is OFF in this position.

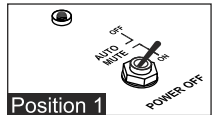

Position 2: Power is ON, AUTO MUTE feature is activated in this position.

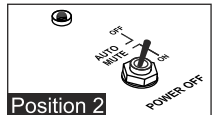

Position 3: Power is ON, but in this position, the system works without AUTO MUTE feature.

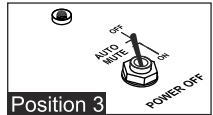

8. Speaker for attendant
This speaker enables the attendant to listen to the customer's voice. Level of sound in this speaker is adjusted from the LISTEN control.

• Controls & Features

(Attendant Unit's Rear View)

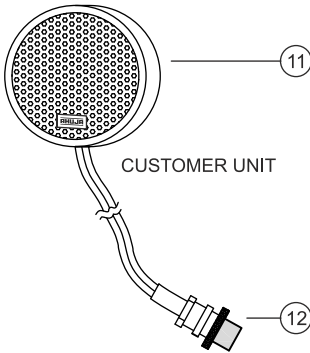
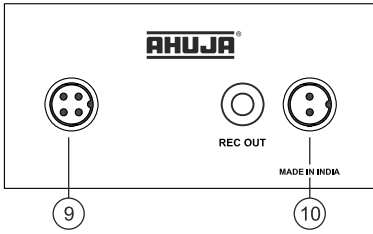

POWER SUPPLY UNIT
(Front View)

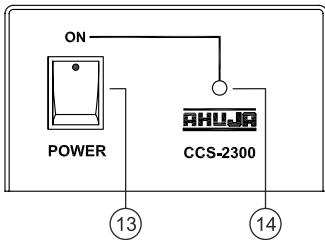

(Rear View)

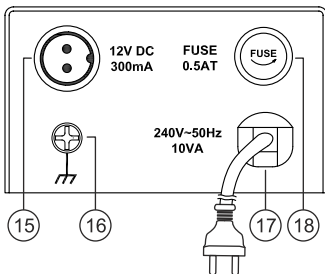

9. **4-Pin Male Socket**
Connect the 4-pin female plug coming from the customer unit to this 4-pin male socket fitted in the Attendant Unit.
10. **2-Pin Male Socket**
Connect the 2-pin female plug, coming from the power supply unit, to this socket.
11. **Customer Unit**
To be fitted on the customer side of the barrier. It contains an omnidirectional condenser mic element and an efficient speaker.
12. **4-Pin Female Plug with cable**
For connecting the Customer Unit to the Attendant Unit.
13. **Power Switch**
Push the top part of the knob to switch the power supply unit ON. Push the bottom part of the knob to switch the power supply unit OFF.
14. **Power LED**
This RED LED glows to indicate that the power supply unit is ON.
15. **2-Pin Male Socket**
Provides 12V DC output for the Attendant Unit
16. **Earthing Screw**
17. **2-Core AC Mains cable with plug.**
18. **AC Mains Fuse** (rating 0.5 Amp 250V)

Installation of the CCS-2300 Customer Unit is elementary and can be done in several different ways.

Method-1: Fixing the Customer Unit on Stone Slab with Tape:

The round Customer Unit is to be fixed horizontally on the stone slab in front of the customer, as shown in Fig. 3. Decide the location of the customer unit in such a way that it is not far from where the customer will stand, and yet does not obstruct any transactions through the cutout which may have been provided in the glass barrier.

Step-1: Take the self sticking “Dual Lock” tape, and pull apart its two parts.

Step-2: Clean the rear surface of the customer unit. Take one part of the “Dual Lock” tape and peel off the transparent release paper on which “Dual Lock” is printed. Then paste the tape firmly in the middle of the two tapped holes, as per drawing marked Fig. 1. Press the tape with the hand several times to make sure it is fixed securely to the customer unit.

Step-3: Clean the desired location on the stone slab. Take the other part of the “Dual Lock” tape and peel off the transparent release paper on which “Dual Lock” is printed. Then paste the tape firmly on the stone slab at the spot where the centre of the customer unit will come as per drawing marked Fig. 2. Press the tape with the hand several times to make sure it is fixed securely to the stone slab.

Step-4: Fix the customer unit to the tape which has been put on the stone slab. Pass the connecting cable under the stone slab by drilling a hole in the slab, or through any alternate route.

Step-5: Locate the Attendant Unit at a suitable place on the attendant's table. Connect the 4 pin connecting cable coming from the Customer Unit to its appropriate connector on the back plate of the Attendant Unit.

Step-6: Ensure that the connecting cable is neatly routed and suitably anchored. Rotate the TALK & LISTEN volume controls to ‘O’ position and flick the toggle switch to POWER OFF Position. Connect the 2-pin DC supply connector to the 12V DC output of the power supply unit. Now connect the AC mains cord of the power supply unit 220-240V, 50Hz AC output and switch ON the unit. Adjust TALK & LISTEN controls suitably.

Fig. 1

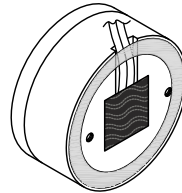
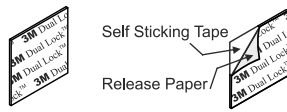

Fig. 2

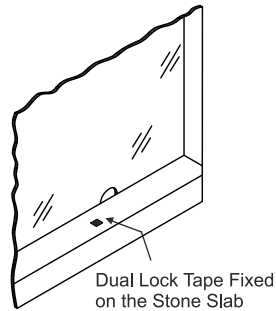
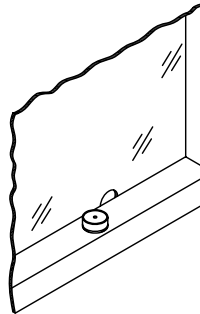

Fig. 3



• Installation Procedure

Method-2: Fixing the Customer Unit on Glass* Panel with Screws :

The round Customer Unit is to be fixed vertically (with screws) on the glass barrier in front of the customer, as shown in Fig.4. Decide the location of the customer unit in such a way that it is not far from where the customer will stand, and yet does not obstruct eye contact between customer and attendant.

Step-1: Drill 3 holes in the glass as per drawing marked Fig.1. Two are for the fixing moulded screws (which are provided), and the third is for the connecting cable.

Step-2: Place the Customer Unit flush against the glass from the outside (customer side) and bring the connecting cable inside (into the attendant's cabin) through the central hole as per drawing marked Fig. 2. Rough edges should not damage the cable. Align the two other holes in the glass with the corresponding holes made in the Customer Unit for the moulded screws. Tighten the moulded screws from inside (from the attendant's cabin), as per drawing marked Fig. 3.

Step-3: Locate the Attendant Unit at a suitable place on the attendant's table. Connect the 4 pin connecting cable coming from the Customer Unit to its appropriate connector on the back plate of the Attendant Unit.

Step-4: Ensure that the connecting cable is neatly routed and suitably anchored. Rotate the TALK & LISTEN volume controls to 'O' position and flick the toggle switch to POWER OFF Position. Connect the 2-pin DC supply connector to the 12V DC output of the power supply unit. Now connect the AC mains cord of the power supply unit 220-240V, 50Hz AC output and switch ON the unit. Adjust TALK & LISTEN controls suitably.

* It is not possible to drill holes in some varieties of glass panels eg, toughened glass. It is important to seek the opinion of an expert.

Fig. 1

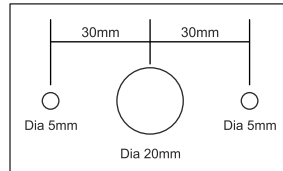

Fig. 2

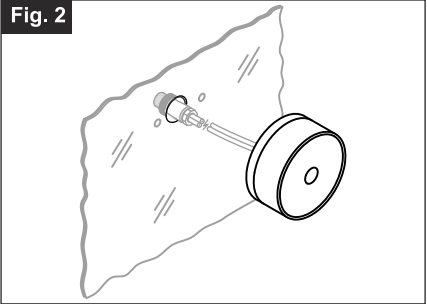

Fig. 3

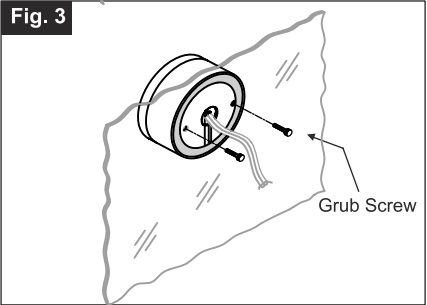
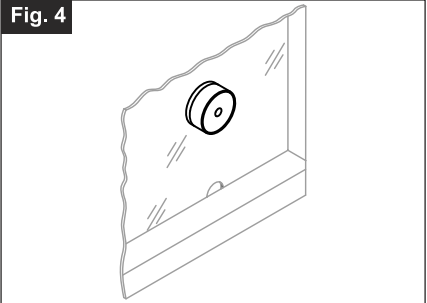

Fig. 4



Method-3: Fixing the Customer Unit on Glass Panel with Tape :

The round Customer Unit is to be fixed vertically (with the “Dual Lock” tape provided) on the glass barrier in front of the customer, as shown in *Fig. 3*. Decide the location of the customer unit in such a way that it is not far from where the customer will stand, and yet does not obstruct eye contact between customer and attendant.

Step-1: Take the self sticking “Dual Lock” tape, and pull apart its two parts.

Step-2: Clean the rear surface of the customer unit. Take one part of the “Dual Lock” tape and peel off the transparent release paper on which “Dual Lock” is printed. Then paste the tape firmly in the middle of the two tapped holes, as per drawing marked *Fig. 1*. Press the tape with the hand several times to make sure it is fixed securely to the customer unit.

Step-3: Clean the desired location on the glass barrier. Take the other part of the “Dual Lock” tape and peel off the transparent release paper on which “Dual Lock” is printed. Then paste the tape firmly on the glass barrier at the spot where the centre of the customer unit will come, as per drawing marked *Fig. 2*. Press the tape with the hand several times to make sure it is fixed securely to the glass barrier.

Step-4: Fix the customer unit to the tape which has been put on the glass barrier & route the connecting cable through the channel provided for this purpose on the rear of the Customer Unit.

Step-5: Locate the Attendant Unit at a suitable place on the attendant's table. Connect the 4 pin connecting cable coming from the Customer Unit to its appropriate connector on the back plate of the Attendant Unit.

Step-6: Ensure that the connecting cable is neatly routed, and suitably

anchored. Rotate the TALK & LISTEN volume controls to ‘O’ position and flick the toggle switch to POWER OFF Position. Connect the 2-pin DC supply connector to the 12V DC output of the power supply unit. Now connect the AC mains cord of the power supply unit 220-240V, 50Hz AC output and switch ON the unit. Adjust TALK & LISTEN controls suitably.

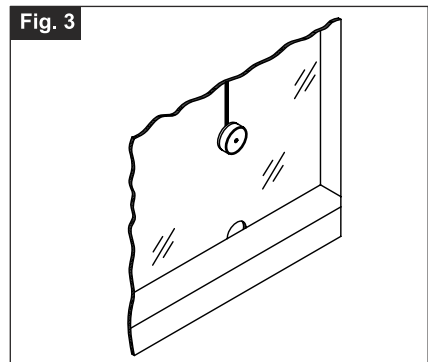
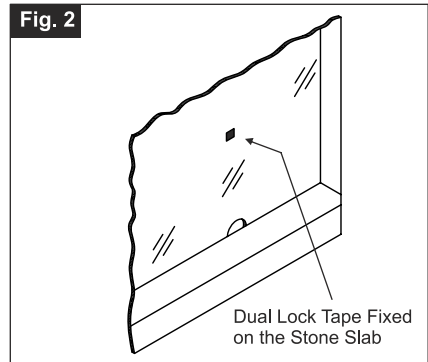
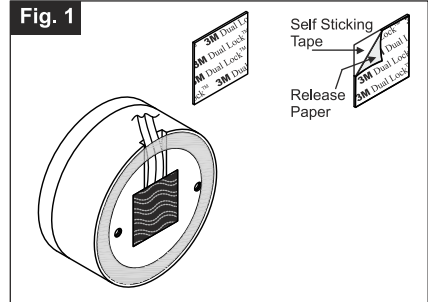

• Operating Procedure

1. Place the Attendant Unit at a suitable location and adjust the long gooseneck shaft to enable the attendant to speak with mouth close to the microphone. Use a foam windshield over the microphone grill.
2. Connect and switch ON the power supply unit. The unit is switched ON by moving the toggle switch to AUTO MUTE OFF (top) or AUTO MUTE ON position. The red LED glows to indicate the power ON status of the unit.
3. Adjust the TALK volume control to a position where the attendant is clearly audible to the customer standing outside when the attendant is speaking at a distance of maximum 2" from the gooseneck microphone, and the green TALK LED is glowing to indicate that the attendant microphone is picking up the attendant's voice. (Whenever the TALK LED goes off, it will indicate that the attendant is not audible to the customer.)
4. Now, adjust the LISTEN volume control to a position where a customer, standing in the expected normal position, is clearly audible to the attendant.

Even if the customer is speaking loudly into the customer unit, ensure that the green TALK LED does not glow (unless the attendant is speaking). If TALK LED glows due to the customer's voice, then adjust the TALK volume control to a lower position to ensure that outside customer's voice is not picked up by the attendant's mic inside.
5. The optimum settings of TALK & LISTEN volume controls should be recorded by the user for future reference. Suitable red dots are provided, which can be pasted on the Attendant Unit to mark the correct setting of the two volume controls.
6. When there is no customer at the counter, then the outside ambient noise can be disturbing for the attendant. To avoid this, the AUTO MUTE ON position on the toggle switch has been provided. In this position, the outside Customer Mic will be partially attenuated after approx. 30 seconds. The LISTEN level will return to normal as soon as the Attendant speaks into his microphone. (In AUTO MUTE OFF position, the Customer Mic will not attenuate).
7. The effect of TALK & LISTEN volume control setting remains the same whether AUTO MUTE is ON or OFF.

• Description of Special Features

1. Voice Operated Attendant Microphone

The Attendant Microphone is normally OFF unless it is triggered by speech of the attendant.

The optimum setting of TALK volume control, on normal speech levels, can be achieved only if the distance from attendant microphone is 2" or less. This also helps in preventing the picking up of inside conversations which are not meant for outside customers. Customer Unit mic is

automatically switched OFF when attendant mic is being used, and green TALK LED on the attendant unit is glowing.

2. AUTO MUTE Function

In AUTO MUTE ON condition, the Customer Mic gets partially muted (attenuated) if it is not used for 30 seconds, (approx.). In order to overcome this muting and restore normal operation, the attendant must speak once through his microphone.

• Specifications

MODEL	CCS-2300
OUTPUT	: 2W (Max.) in each amplifier
MICROPHONE ELEMENT:	Electret Condenser in both the units.
AUTO MUTE 'ON'	: Enables after 30 seconds (approx.)
POWER REQUIREMENT	: AC: 220-240V, 50/60Hz
PROTECTIONS	: AC Fuse 1 × 0.5A
DIMENSIONS	
Attendant Unit	: W116 x H65 x D170mm (w/o gooseneck)
Customer Unit	: Ø98 x D52mm
Power Supply Unit	: W85 x H58 x D150mm
WEIGHT	
Attendant Unit	: 1.3kg approx.
Customer Unit	: 0.55kg approx.
Power Supply Unit	: 0.93kg approx.
ACCESSORIES	: 1 No. of fuse 0.5A, 2 Nos. of M4 moulded screws, 2 Nos. of self adhesive DUAL LOCK tape

AHUJA RADIOS • 215, Okhla Industrial Estate, New Delhi - 110 020, INDIA

Tel.: +91-11-26831549, 41612474 Fax: +91-11-26847287

E-mail: ahuja@ahujaradios.com Website: www.ahujaradios.com

The logo for Ahuja Radios features the word "AHUJA" in a bold, white, sans-serif font. The letters are contained within a white rectangular frame that has horizontal bars extending from the top and bottom edges. A registered trademark symbol (®) is positioned to the upper right of the word.

- Design and Specifications are subject to change without notice owing to continuous product up-gradation
- Technical specifications are subject to production tolerances.
- We cannot be held responsible for printing errors, should they occur.
- **AHUJA** is a registered trademark of Ahuja Radios in India and other countries.
- © Copyright Ahuja Radios, 2014. All rights reserved. Any unauthorized reproduction or use of logos, images or design elements is strictly prohibited by law.
- No part of this compilation may be reproduced in any manner or translated without written permission.