

# AHUJA®

# PA MIXER

OPERATION MANUAL

## PMX-1032DFX

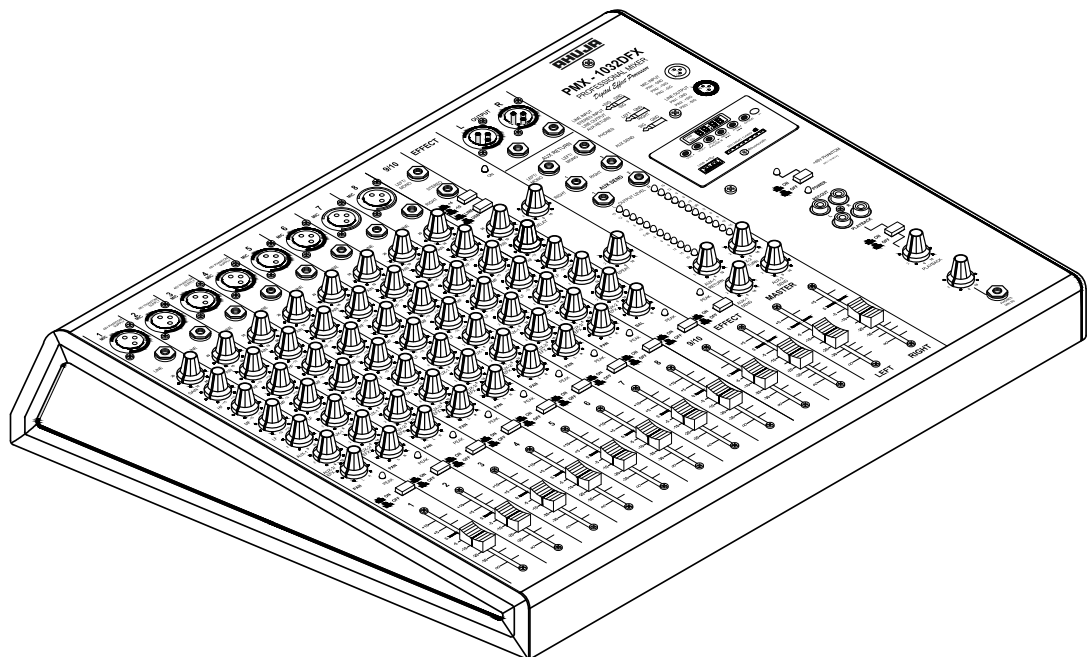

- ◆ Please read this manual thoroughly before making connections and turning on the power. Following the instructions in this manual will enable you to obtain optimum performance from your new AHUJA PA Mixer.
- ◆ Please retain this manual for future reference.

## • Safety Instructions

**Read the Instructions:** Please read all the instructions in this section carefully before installation or use of the product. All the safety instructions must be followed.

**Retain the Instructions:** Please retain this Instruction Manual for future reference.



This symbol, wherever it appears, alerts you to the presence of uninsulated hazardous voltage that may be sufficient to constitute a risk of electric shock. External wiring to any terminal marked with this symbol must be done by a trained and instructed person only.



This symbol, wherever it appears adjacent to a component, alerts you that the concerned component can only be replaced by another of the exact same specifications.

### **WARNING**

To reduce the risk of electric shock, do not remove the cover. No user serviceable parts inside. Refer all servicing to qualified personnel only.

### **CAUTIONS**

**Water & Moisture:** To reduce the risk of fire or electrical shock, do not expose this set to rain or moisture. Do not use this set near water or in a wet location. Do not keep any object filled with liquid, such as a vase, on top of this set. Do not insert or remove the AC mains plug with wet hands.

**Power Source:** The voltage & frequency of the AC mains supply, to which this set can be connected, is marked on the rear panel of the set. Do not connect this set to any power source other than that specified on the rear panel.

**Power Cord Protection:** Do not cut, kink, damage or modify the AC power cord supplied with this set. Keep the AC power cord away from heaters and harmful chemicals. Do not keep any heavy object on the power cord.

**Operation on Generator:** When operating this set on a generator, make sure the set is switched off till the generator voltage has stabilized.

**Stability:** This set must be kept in a stable and flat horizontal position, and never in a tilted position. Do not place this set on an unstable stand, tripod, bracket or mount. Do not use attachments which are not supplied or explicitly recommended by the manufacturer.

**Earthing:** This set must be earthed properly before use. A wire from the Earth terminal on the rear panel must be connected to electrical earth.

**Cleaning:** Disconnect this equipment from the AC mains before cleaning. Clean with a damp cloth, but do not allow any liquid to enter the set. Do not clean with liquids or aerosols.

## • Table of Contents

<b>Contents</b>	<b>Page No.</b>
• <b>Features / General Description of Product</b> . . . . .	<b>4</b>
• <b>Top and Rear Panel</b> . . . . .	<b>5</b>
• <b>The Mic / Line Input Section</b> . . . . .	<b>6</b>
• <b>The Stereo Input Section</b> . . . . .	<b>7</b>
• <b>The Output Section</b> . . . . .	<b>8</b>
• <b>The Effect Section</b> . . . . .	<b>9</b>
• <b>The Tape &amp; Headphone Section</b> . . . . .	<b>10</b>
• <b>The Power Supply Section</b> . . . . .	<b>10</b>
• <b>MP3 Playback Facility: Controls &amp; Features</b> . . . . .	<b>11</b>
• <b>Operation</b> . . . . .	<b>12</b>
• <b>Pairing of Bluetooth Device</b> . . . . .	<b>13</b>
• <b>Plugs Wiring Details</b> . . . . .	<b>13</b>
• <b>Applications</b> . . . . .	<b>14</b>
• <b>Specifications</b> . . . . .	<b>16</b>

## • Features/General Description of Product

- n Rugged, reliable, high quality analog mixer with user-friendly construction & aesthetically designed side panels.
- n Eight MIC/LINE Balanced Mono inputs with enhanced headroom.
- n One STEREO Balanced input in two selectable sensitivities of -10dBu & +4dBu.
- n MP3 playback facility is available through a built-in MP3 module which is switchable with the stereo channel.
- n MP3 player with remote, facilitates playback of audio content through USB, Pen drive, SD Card or bluetooth.
- n Separate EFFECT channel is provided for controlling the built-in digital effect processor through DELAY, REPEAT and EFFECT LEVEL controls.
- n All MIC inputs are through 3 pin F/XLR connectors.
- n All LINE & STEREO inputs are through 6.3mm stereo phone jack sockets.
- n Four MIC inputs (MIC-1 to MIC-4) are available with 48V phantom supply which can be switched ON/OFF through a common switch.
- n Each MIC/LINE channel has a GAIN control, 3 band active equalizer controls, a pre-fader AUX1 control, a post-fader AUX2 /EFX control, a PAN control and a channel fader control.
- n STEREO channel has a GAIN control, 2 band active equalizer controls, AUX1 pre fader control, AUX2/EFX post fader control, a BALANCE control and a channel fader control.
- n Channel ON/OFF switch provided on each individual channel.
- n Peak LED for prior indication of signal clipping.
- n High precision 60mm slide fader on each channel.
- n Balanced Left & Right Line outputs through M/XLR connectors as well as 6.3mm stereo phone jack sockets.
- n Easy and accurate monitoring of Left & Right output levels through individual 12 segment LED array.
- n Two AUX SEND outputs with level controls: one each for monitoring and effects processing applications.
- n Two stereo AUX RETURN balanced inputs with level controls.
- n Headphone output with a level control for output monitoring.
- n Stereo Tape Playback input through L&R RCA sockets provided with ON/OFF switch & level control.
- n Stereo Record output through L&R RCA sockets.
- n Operates on 240V 50Hz AC mains.

# • Top and Rear Panel

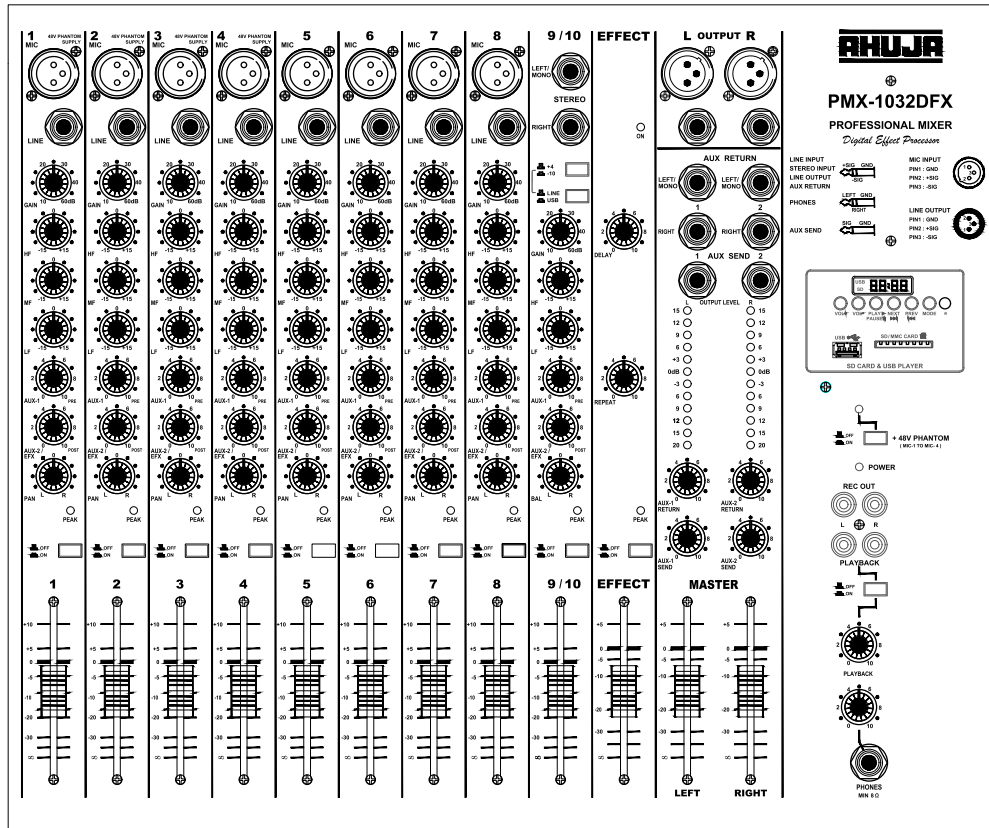

TOP PANEL

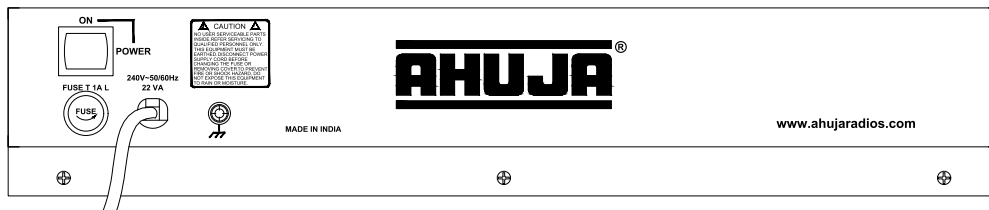

REAR PANEL

## • The Mic / Line Input Section

### 1. (a) MIC INPUT (Channel 1 to Channel 4)

For connecting phantom powered condenser microphone through a 3 pin XLR connector in balanced mode. Keep 48V phantom switch in ON position whenever a phantom microphone is connected. If no phantom microphone is being used, then keep phantom switch to OFF so that channel 1 to channel 4 can be used for connecting low impedance dynamic or condenser (self-powered) microphone.

### (b) MIC INPUT (Channel 5 to Channel 8)

For connecting low impedance dynamic & condenser (self-powered) microphone through 3 pin XLR connector, either in balanced or unbalanced mode. Refer to "Plugs Wiring Details" on page 13 of this manual.

### 2. LINE INPUT

For connecting signal sources like CD players, Keyboards etc. through a 6.3mm stereo phone jack, either in balanced or unbalanced mode. Refer to "Plugs Wiring Details" on page 13 of this manual.

### 3. GAIN CONTROL

The input level of both the Mic & Line signals can be adjusted by this control. It provides a gain range of more than 45dB.

### 4. HF CONTROL

It is used to obtain a 12dB cut or boost (shelving type) at 10kHz as center frequency.

### 5. MF CONTROL

It is used to obtain a 12dB cut or boost (peaking type) at 2kHz as center frequency.

### 6. LF CONTROL

It is used to obtain a 12dB cut or boost (shelving type) at 100Hz as center frequency.

### 7. AUX-1 CONTROL

This control is used to adjust the level of pre-fader signal of a channel which is then routed to AUX-1 SEND OUTPUT.

### 8. AUX-2 CONTROL

This control is used to adjust level of post-fader signal of a channel which is then routed to the AUX-2 SEND OUTPUT.

### 9. PAN CONTROL

The signal of mono input channels is distributed into LEFT & RIGHT line outputs. The PANORAMA (PAN) control is used to adjust the relative levels of the L & R outputs of this distributed signal.

### 10. PEAK LED

This RED LED lights up to indicate that either the input signal is overloading the input circuit or the GAIN control setting is high enough to distort the signal. Both conditions can be overcome by appropriate adjustment of GAIN control. Please ensure that this LED is NOT continuously ON.

### 11. ON/OFF SWITCH

This push switch is useful in switching individual channels ON or OFF during setting-up of equipment. Also, the channels which are not in use, during a program, can be switched OFF through this switch.

### 12. CHANNEL FADER

This slide volume control adjusts the level of pre-amplified mono signal prior to panning action.

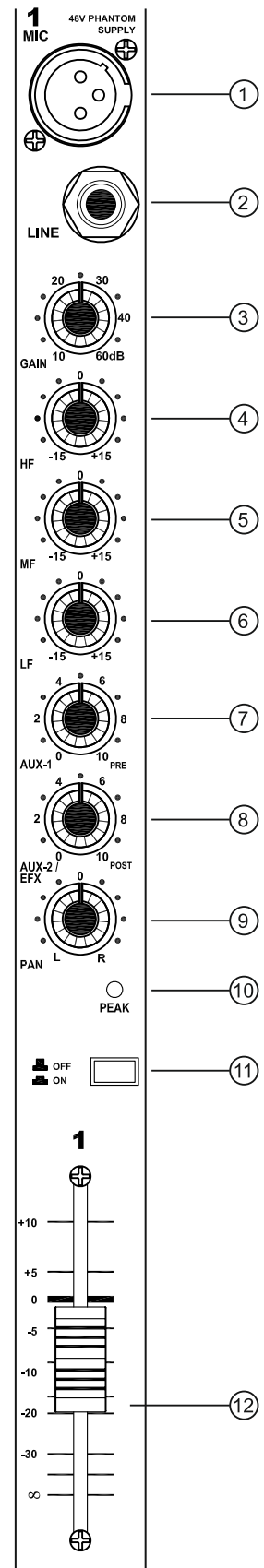

## • The Stereo Input Section

### 1. STEREO LINE INPUT

For accepting balanced stereo line level signals through 6.3mm stereo phone jack sockets. However, these inputs can also accept either unbalanced stereo signals, balanced mono signals or unbalanced mono signals. Sources like CD Player, DVD Player, Computer line out etc. can be connected to the stereo input channel.

### 2. LEVEL SELECTOR SWITCH (For Stereo Line Input)

This push switch helps in selecting the sensitivity for stereo line inputs between +4dB (high) & -10dB (low) signal levels.

### 3. LINE/USB SELECTOR SWITCH

This push switch helps in selection between LINE mode or USB mode. When the USB mode is selected, then the gain of the USB signal can be adjusted by the stereo gain control of this channel.

### 4. STEREO GAIN CONTROL

The level of both left & right input signals (LINE or USB) can be adjusted by this control. It provides a gain range of more than 45dB.

### 5. STEREO HF CONTROL

It is used to obtain a 12dB cut or boost (shelving type) at 10kHz as center frequency.

### 6. STEREO LF CONTROL

It is used to obtain a 12dB cut or boost (shelving type) at 100Hz as center frequency.

### 7. AUX-1 CONTROL

This control is used to adjust the level of pre-fader signal which is to be routed to AUX-1 SEND OUTPUT.

### 8. AUX-2 CONTROL

This control is used to adjust level of post-fader signal which is to be routed to the AUX-2 SEND OUTPUT.

### 9. STEREO BALANCE CONTROL

The distribution level of stereo signal into the left & right line outputs is adjusted through this control.

### 10. PEAK LED

This RED LED lights up to give prior indication that either the signal is overloading the input circuit or the GAIN control setting is high enough to distort the signal. Both conditions can be overcome by appropriate adjustment of GAIN control. Please ensure that this LED is NOT continuously ON.

### 11. ON/OFF SWITCH

This push switch is useful in switching individual channels ON or OFF during setting-up of equipments. Also, the channels which are not in use during a program, can be switched OFF through this switch.

### 12. STEREO CHANNEL FADER

This slide volume control adjusts the level of pre-amplified mono signal prior to balancing action.

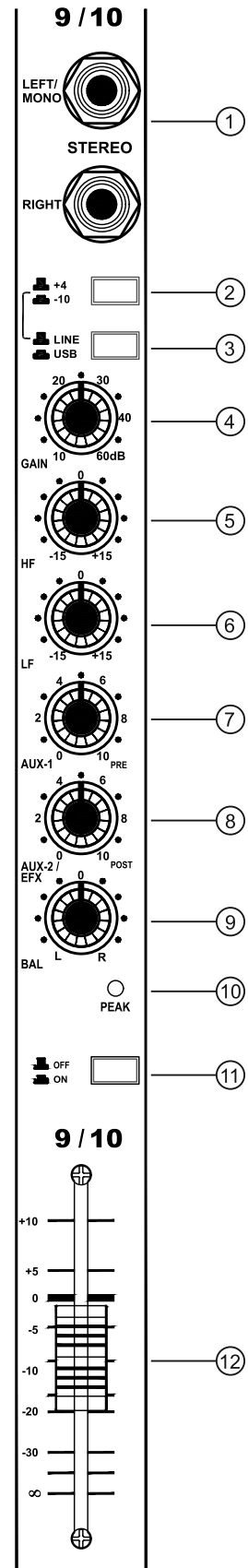

## • The Output Section

### 1. LINE OUTPUT

Balanced Line outputs have been provided for the LEFT & RIGHT channels through individual 3 Pin M/XLR connectors as well as 6.3mm phone jack sockets. For making balanced and unbalanced output connections, refer to "Plugs Wiring Details" page 13 of this manual.

### 2. STEREO AUX RETURN INPUTS

There are two Stereo Aux Return Inputs: Aux Return 1 & Aux Return 2. Both inputs are designed for accepting balanced stereo signals through 6.3mm stereo phone jack sockets. However, these inputs can also accept either unbalanced stereo signals, balanced mono signals or unbalanced mono signals. The Aux return input signals are directly mixed with the L&R main mix signals so that it is available at LINE OUTPUT, REC OUTPUT & Headphone Output.

### 3. AUX-1 SEND OUTPUT

It provides the combined pre-fader output of all the input channels through a 6.3mm mono phone jack. The pre-fader output is mainly used for stage monitoring application.

### 4. AUX-2 SEND OUTPUT

It provides the combined post-fader output of all the input channels through a 6.3mm mono phone jack. The post-fader output is mainly used for external processing by effects unit, reverb unit etc.

### 5. LEFT & RIGHT OUTPUT LEVEL LED INDICATOR

The output signal level from Left & Right channels is indicated by an individual 12 segment LED array. Each LED array is calibrated to display output signal levels varying from -20dB to +15dB. 0dB LED glows to indicate the rated output level of +4dBu.

### 6. AUX-1 RETURN CONTROL

This is a two track volume control for adjusting the level of signals being fed to Stereo/Mono AUX-1 Return inputs.

### 7. AUX-2 RETURN CONTROL

This is a two track volume control for adjusting the level of signals being fed to Stereo/Mono AUX-2 Return inputs.

### 8. AUX-1 SEND CONTROL

For adjusting the output level of pre-fader signal which is taken from AUX-1 SEND Output phone jack.

### 9. AUX-2 SEND CONTROL

For adjusting the output level of post-fader signal which is taken from AUX-2 SEND Output phone jack.

### 10. LEFT MASTER CONTROL

It controls the signal level of the LEFT channel LINE output which is available through XLR / Stereo Phone Jack.

### 11. RIGHT MASTER CONTROL

It controls the signal level of the RIGHT channel LINE output which is available through XLR / Stereo Phone Jack.

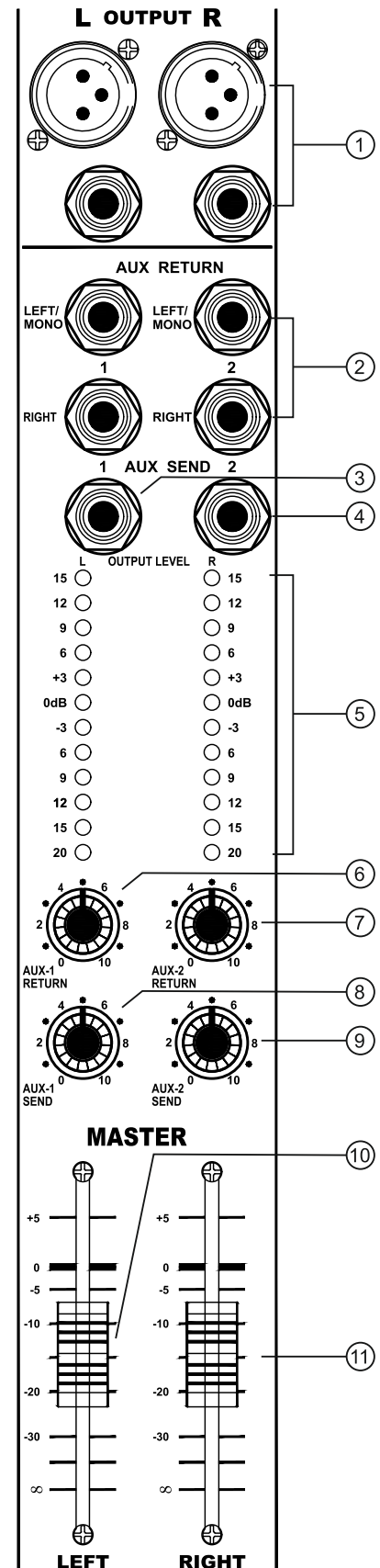



## • The Effect Section

### 1. EFFECT CHANNEL LED

The red LED glows to indicate that the built-in effect section is switched ON.

### 2. DELAY CONTROL

For setting the delay time according to the desired application. For example in speech applications, the delay control may be adjusted towards the lower position and for singing applications, the delay control may be adjusted towards a higher position .

### 3. REPEAT CONTROL

For setting the number of repetitions within the selected delay time. For example in speech the repeat may be adjusted towards lower position whereas for singing it may be adjusted towards a more higher position.

### 4. PEAK LED

The red LED glows to indicate that the effect signal is distorting. The effect fader control should be adjusted so that this LED is NOT continuously lighted up.

### 5. EFFECT ON/OFF SWITCH

For switching the effect function ON or OFF during setting up and while in live programme. Keep the switch in OFF position if digital effects are not in use.

### 6. EFFECT FADER

For setting the level of delay signal in the overall output signal. Nominal position of this level control can be near '0' position. However, more thrust/impact can be generated in initial repeat signals by setting this control towards maximum (+5) position.

| **ECHO** - Echo Effect is used to repeat the original sound many times to give multiple voice effect and is used for vocals.

| **REVERB** - Reverb is used for giving Hall Effect to the original sound as repeated reflecting sound raises overall level of the signal. This is also used for public announcement in Stadia and Open Air Performances.

| **CHORUS** - Chorus Effect is used by a singer to create an effect as if a Group is performing.

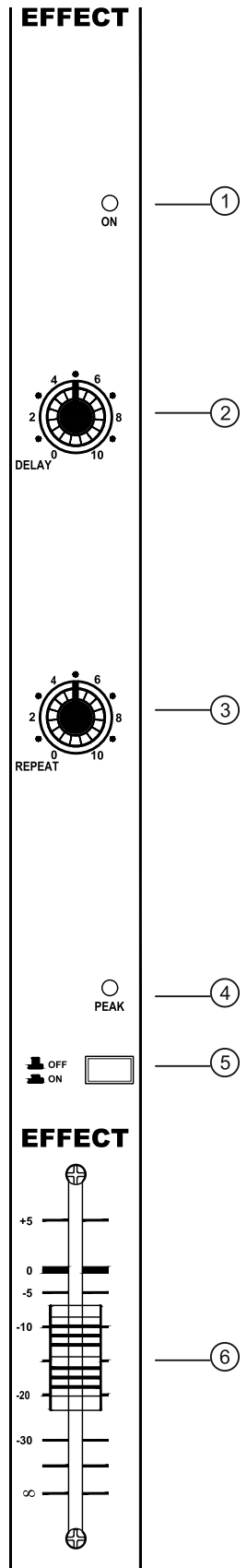

## • The Tape & Headphone Section

- 48V PHANTOM LED**  
The red LED glows to indicate that phantom supply to Channel 1, 2, 3 & 4 microphone inputs has been switch ON.
- 48V PHANTOM ON/OFF SWITCH**  
For switching the phantom supply ON or OFF. When this switch is ON, phantom power condenser microphone can be connected on mic input channels 1 to 4.
- POWER LED**  
The RED LED glows to indicate that the 240V AC mains supply has been switched ON by the mixer's power switch.
- STEREO RECORDING OUTPUT**  
The stereo unbalanced recording output is available through individual left and right RCA sockets. This output can be used to record the main stereo mix signal from the mixer onto a tape recorder, CD recorder etc. Also, an additional power amplifier can be connected to these RCA output sockets. The recording output level is affected by the setting of master fader controls.
- STEREO PLAYBACK INPUT**  
The left & right RCA socket are provided for connecting the stereo unbalanced line level signal from a stereo cassette player, a CD player, a DVD player, a USB player, an IPOD etc. The stereo playback input is an independent input channel, which is directly mixed with the L&R main mix signal. This means that stereo playback signals are available at LINE OUTPUT, REC OUTPUT & Headphone output.
- PLAYBACK ON/OFF SWITCH**  
For switching the playback signal ON or OFF during setting-up & live program.
- PLAYBACK CONTROL**  
It is used to adjust the level of playback signal into the main mix signal.
- HEADPHONE CONTROL**  
It is used for controlling the level of stereo signal which is available as headphone output.
- HEADPHONE OUTPUT**  
For connecting a stereo headphone (not less than 8Ω impedance) through a 6.3mm stereo phone jack. The headphone output is used for personal monitoring & its level is not effected by the setting of master control.

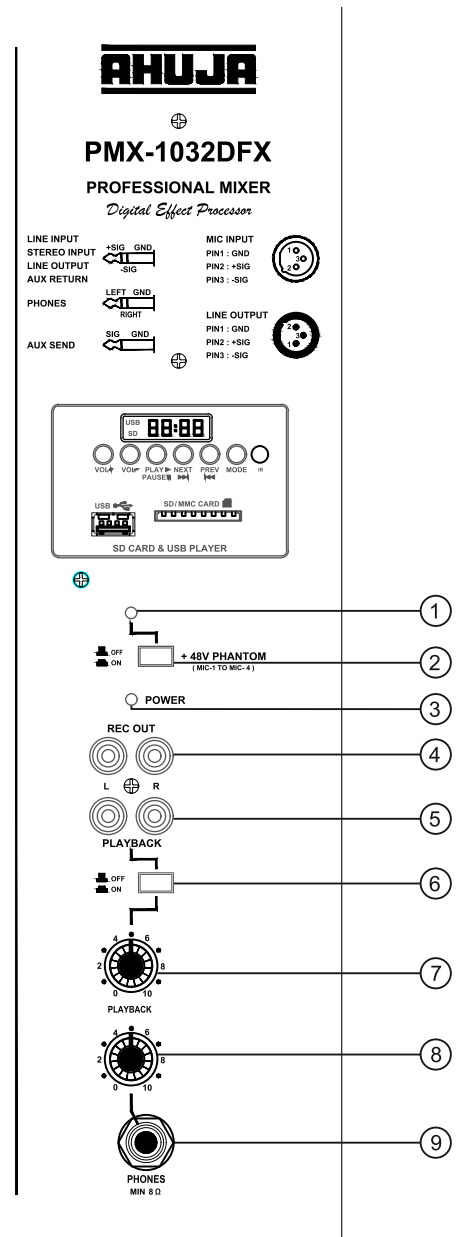

## • The Power Supply Section

- POWER SWITCH**  
Push the top part of the knob to switch the mixer ON. Push the bottom part of the knob to switch the mixer OFF.
- AC MAINS FUSE Rating 1Amp 250V (T 1A L)**  
This protects the mixer from any excessive current flow.
- 2 CORE AC MAINS CABLE WITH PLUG**
- EARTH TERMINAL**

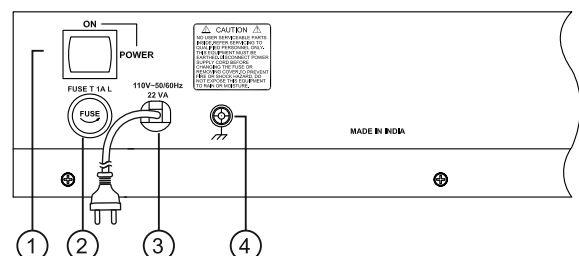

# • MP3 Playback Facility: Controls & Features

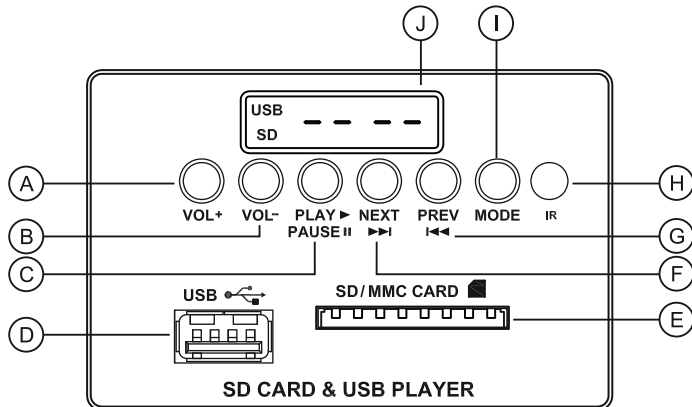

- A. **VOL+ :** To increase volume level of MP3 player.
- B. **VOL- :** To decrease volume level of MP3 player.
- C. **▶|| PLAY/PAUSE:** Press PLAY/PAUSE once to Pause if music is already playing. Press PLAY/PAUSE again to resume playing.
- D. **USB Connector:** Insert the USB drive here. While inserting USB drive into the USB connector, hold the USB drive in such a way that hollow part of the USB drive is downwards as shown in Figure.

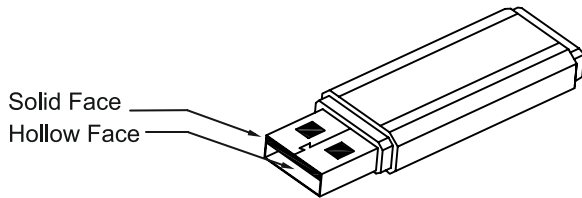

Any forceful insertion in wrong direction will damage the connector.

- E. **SD/MMC Card Connector:** Insert the SD/MMC Card into the slot to play. When taking out the card, push the card to take out.

While inserting SD/MMC card into the slot, ensure that the card is inserted in such a way that all pins are facing upward and cut is towards left as shown in figure.

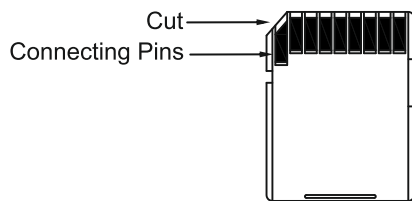

- F. **▶|| Next:** Press NEXT to select next forward music track. Pressing NEXT repeatedly will move the system to successively next forward tracks. Then press PLAY/PAUSE for playing the track so selected.
- G. **◀◀ Prev:** Press PREV to Select the previous track. Pressing PREV repeatedly will move the system to successively previous tracks.
- H. **IR Sensor:** Picks up signal from the Remote control.

## Remote Control

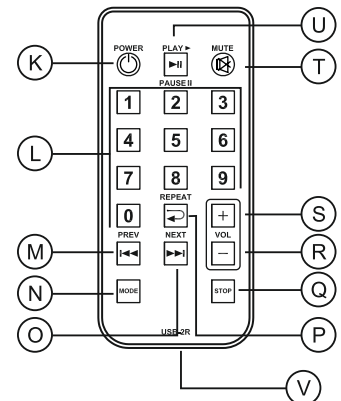

Point the Remote control toward this sensor for best results.

- I. **Mode:** To select USB, SD or Bluetooth when USB SD both are inserted. Default condition of the set is “ \_ \_ \_ ”
- J. **LED Display:** Instantly displays 3 digits of the track selected play to i.e 001 to 999. During play, display the time duration of the track played.

## Remote Control

- K. **Power:** Press once to switch off MP3 player, press again to switch ON.
- L. Number key 0 to 9. To choose the track number to be played.
- M. **◀◀ :** To select the previous track.
- N. **MODE :** To select SD, USB or Bluetooth Option.
- O. **▶▶ :** Press to select the next track.
- P. **↻** Press once to repeat the song being played. Press twice to repeat all the songs.
- Q. **STOP:** Press to stop the track being played.
- R. **Vol:** Press to decrease the volume of MP3 Player.
- S. **Vol:** Press to increase the volume of MP3 Player.
- T. **MUTE:** Press once to mute the sound, press again to resume the sound.
- U. **▶|| PLAY/PAUSE:** Press Play/Pause once to Pause when music is already playing. Press Play/Pause again to resume playing.
- V. **Battery Replacement:** Pull out the battery tray and replace the battery with positive electrode facing upwards as shown in fig. below. Push the battery compartment back to the close position. Use CR2025 or equivalent lithium coin cell.

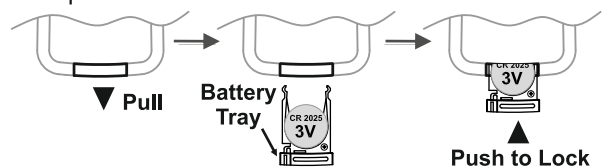

## • Operation

1. Please ensure that AC mains supply to all the equipments is switched OFF.
2. Connect the desired number of input sources like phantom powered microphones, wired microphones, CD player, DVD player, keyboard etc., to the appropriate input sockets of the mixer.
3. Connect the power amplifiers, external processors, recording machine, headphone etc., to the appropriate output sockets of the mixer.
4. All the rotary & slide volume controls of the mixer as well as that of the peripheral equipments should be set to minimum position.
5. All the tone controls (HF, MF & LF), PAN controls & BAL controls should be set at center (FLAT) position.
6. Keep all the push switches of the mixer in OFF position.
7. Connect all the equipments to their respective AC mains supply sockets.
8. Always switch ON the mixer first and all the power amplifiers in the last. In between, other equipments can be switched ON.
9. Now, GAIN control setting should be carried out for channels which have microphone as an input source. The microphone XLR input is designed to accept dynamic and condenser (self powered) microphones in both balanced as well as unbalanced mode of connection. The microphone XLR input channels 1 to 4 can be used for connecting condenser (phantom powered) microphones in balanced mode of connection.
10. Press the microphone channel switch to ON.
11. Switch the microphone ON and speak a few words through it while turning up the GAIN control to a position where the PEAK LED just starts to flicker.
12. Now speak loudly into the microphone and then readjust the GAIN control to a position where the PEAK LED just flickers.
13. For desired tonal balance, adjust HF, MF & LF controls and then carry out the final setting of GAIN control as explained in point #12. The setting of tone controls can be different for each microphone input channel.
14. Similarly, the setting of GAIN control for LINE input channels should be done with reference to the setting of tone controls & flickering of the PEAK LED.
15. The setting of GAIN control for STEREO input channels should also be done in a similar way as explained in point #14.
16. After completing the GAIN setting of all the channels, adjust the slide control of each channel to obtain the desired mix at the output.
17. For using the built-in digital effect processor, put ON the Effect switch and select the desired range of delay settings. Obtain the desired echo or reverb effect from delay control & number of repetitions from repeat control. The level of this processed signal should be adjusted through AUX-2/EFX control in each channel and then through Effect control in the EFFECT channel.
18. The overall level of LEFT & RIGHT LINE output signals should be adjusted through respective MASTER slide controls.
19. Use PAN control to adjust the level of mono input signal which is contributed to LEFT & RIGHT channels.
20. Use BAL control to adjust the level of stereo (or L/mono) input signal which is contributed to LEFT & RIGHT channels.
21. The level of pre-fader output of each input channel, that is contributed to the main AUX-1 Send output, should be adjusted through AUX-1 control of that channel.
22. Similarly, the post-fader output of each input channel, that is contributed to the main AUX-2 Send output, should be adjusted through AUX-2 control of that channel.
23. The post-fader signals, after external processing, are fed back to the mixer through AUX RETURN inputs and mixed with the main L & R outputs through AUX-1 RETURN volume controls.
24. For operating USB module, keep LINE/USB switch in USB position. For detailed operation of MP3 module refer MP3 Playback Facility Control & Features on page # 11
25. Always use interconnecting cables with appropriate connectors which are suitably wired for proper functioning of the mixer & its peripheral equipments.

## • Pairing of Bluetooth Device

SWITCH ON the mixer in use. The Default condition of the MP3 digital Player is USB/SD mode. The display shows \_\_\_\_\_.

To play the MP3 programme from mobile phone or laptop via bluetooth, the PAIRING of the Bluetooth devices of mobile phone & mixer is necessary. To use Bluetooth, Press Mode switch to select Bluetooth.

### Pairing is done as follows :-

SELECT the Bluetooth option in Mobile Phone or laptop & follow the instructions appearing on mobile/laptop screen.

### Normally the following general instructions are followed\*:

Press ACTIVATE /ON/DISCOVERABLE/SEARCH, etc, as applicable in the mobile phone or laptop used.

The mobile phone or laptop starts searching for the new Bluetooth device. The moment Bluetooth appears on the mobile phone or laptop, select the new device i.e. Bluetooth and press OK or allow it to appear on mobile. System is ready to use.

In some mobiles, it asks for a code to allow access. Press 0000 and follow the steps, like pressing "OK", "Allow once", "Allow always" etc. and make the device ready for use.

Select the MP3 programme from mobile phone or laptop and press PLAY. The same song starts playing on the Ahuja mixer. We can SELECT Volume, Fast Forward, Rewind, Play/Pause function either from keys on the mixer or through Remote Control.

**Note:** It is not necessary that all functions of remote control will be activated through Bluetooth and compatibility varies from mobile to mobile.

\* However, some mobile phones/computers may require a different procedure. Please read the user manual of the phone/computer.

## • Plugs Wiring Details

### 1. Pin connections of a 3 pin XLR plug:

#### a) MIC Input:

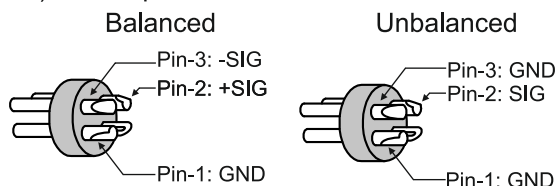

#### b) LINE Output:



### 2. Pin connections of a 6.3mm (1/4") Stereo Phone Plug for LINE Input, STEREO Input, AUX RETURN Input & LINE Output.

#### a) For balanced signal

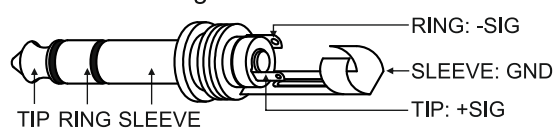

#### b) For unbalanced signal

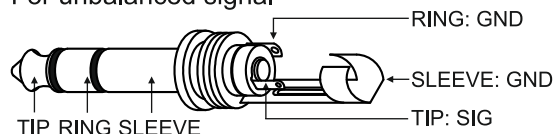

### 3. Pin connection of a 6.3mm (1/4") Mono Phone Plug for connecting unbalanced signal in LINE Input, STEREO Input, AUX RETURN Input, LINE Output and AUX SEND Output.

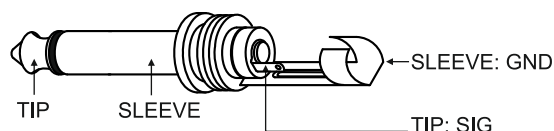

### 4. Pin connections of a 6.3mm (1/4") Stereo Phone Plug for Headphone Output.

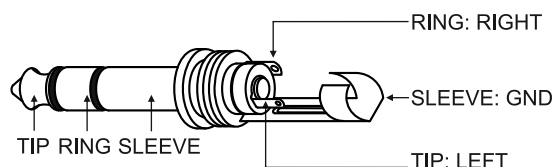

### 5. Pin connection of an RCA plug for RECORD Output and PLAYBACK Input.

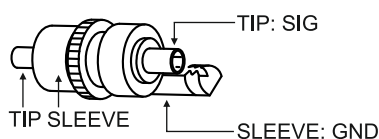

# • Applications

## LIVE PERFORMANCE

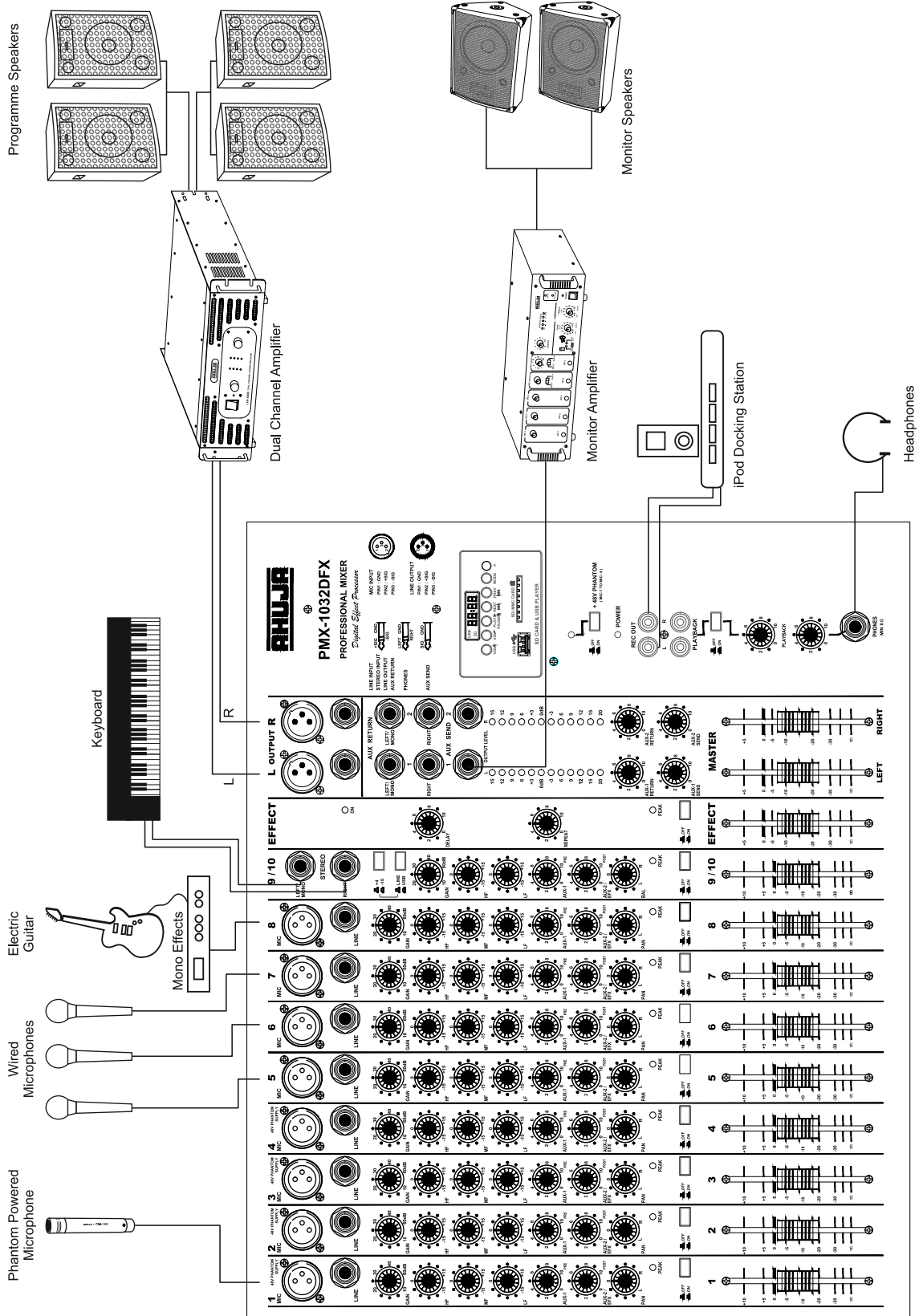

OPEN CONFERENCE / CONVENTION SETUP

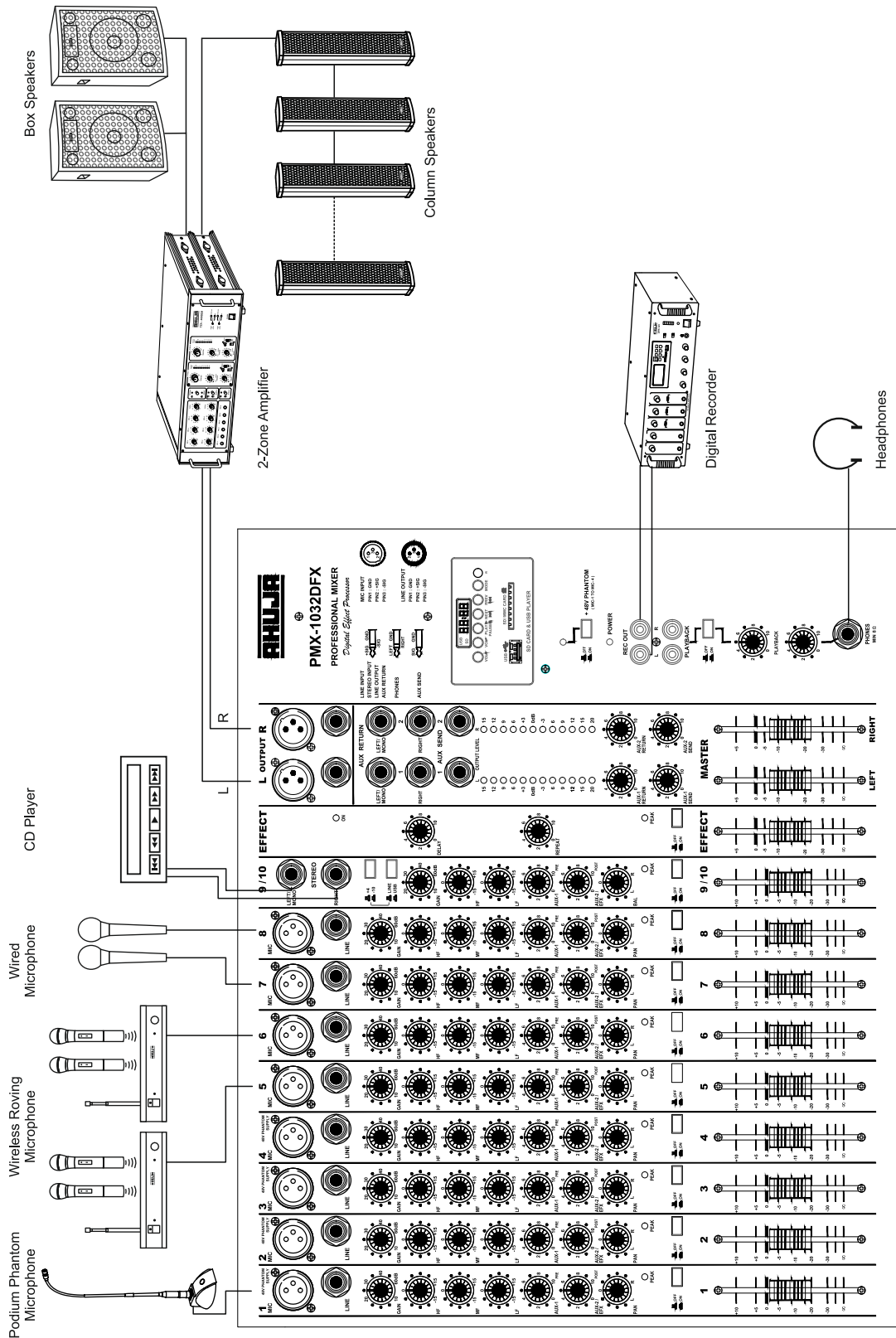

## • Specifications

<b>MIC INPUT</b>	
Impedance/Gain	: 2k $\Omega$ Balanced/65dB
<b>LINE INPUT</b>	
Impedance/Gain	: 20k $\Omega$ Balanced/45dB
<b>STEREO INPUT (L/Mono &amp; R)</b>	
Impedance/Gain (-10dB Input)	: 10k $\Omega$ Balanced/14dB
Impedance/Gain (+4dB Input)	: 10k $\Omega$ Balanced/0dB
<b>THD</b>	: <0.08%
<b>FREQUENCY RESPONSE</b>	
L/R Line Output	: 25Hz - 20kHz (+0, -1dB)
<b>EQUALIZATION</b>	
Bass/Mid/Treble	: $\pm$ 12dB at 100Hz/2kHz/10kHz
<b>CLIP LED INDICATION</b>	: 4 dB prior to true clip
<b>LINE OUTPUT</b>	
Nominal/Max Level	: 4dBu/21dBu (1.22V/9V)
<b>IMPEDANCE</b>	: 600 $\Omega$
<b>DELAY SYSTEM</b>	: Digital Signal Processing
<b>DELAY RANGE SETTINGS</b>	: 30ms-400ms
<b>DIGITAL PLAYER</b>	: MP3 Player with USB, SD/MMC Card Reader and Bluetooth
<b>HEADPHONE OUTPUT</b>	: 200mV at 8 $\Omega$ , THD <1%
<b>MAXIMUM GAIN</b>	
Mic Input to Line Outputs	: 78dB
Line Input to Line Outputs	: 58dB
Stereo Input to Line Outputs	: 28dB (-10dBu Input) 14dB (+4dBu Input)
AUX Send (Pre)	: 1.4V/100 $\Omega$ Unbalanced
AUX Send (Post)	: 2.7V/100 $\Omega$ Unbalanced
AUX Return (L&R)	: 150mV/10k $\Omega$ Balanced
<b>TAPE</b>	
Record Output	: 250mV/600 $\Omega$
Playback Input	: 250mV/1k $\Omega$ (variable thru' GAIN control)
<b>SIGNAL TO NOISE RATIO</b>	: >70dB
<b>POWER SUPPLY</b>	: AC: 220-240V, 50/60Hz
<b>DIMENSIONS</b>	: W465 $\times$ H110 $\times$ D435mm
<b>WEIGHT</b>	: 7.70kg

Design and Specifications are subject to change without notice owing to continuous product up-gradation. Technical specifications are subject to production tolerances.

We cannot be held responsible for printing errors, should they occur. **TRUSOUND** is a registered trademark of Ahuja Radios in India and other countries.

© Copyright Ahuja Radios, 2018. All rights reserved. Any unauthorized reproduction or use of logos, images or design elements is strictly prohibited by law.

No part of this compilation may be reproduced in any manner or translated without written permission.

TRUSOUND PVT. LTD. • C-89, Sector IV, Noida, Gautam Budh Nagar-201 301 (UP)  
 Regd. Office : 125E, Okhla Industrial Estate, New Delhi-110 020  
 Tel.: +91-120-4665665 Fax : +91-120-4665621  
 E-mail: trusoundsupport@airtelmail.in