

AHUJA®

PA Mixer Amplifier

160W RMS/200W Max.

TZA-1500®

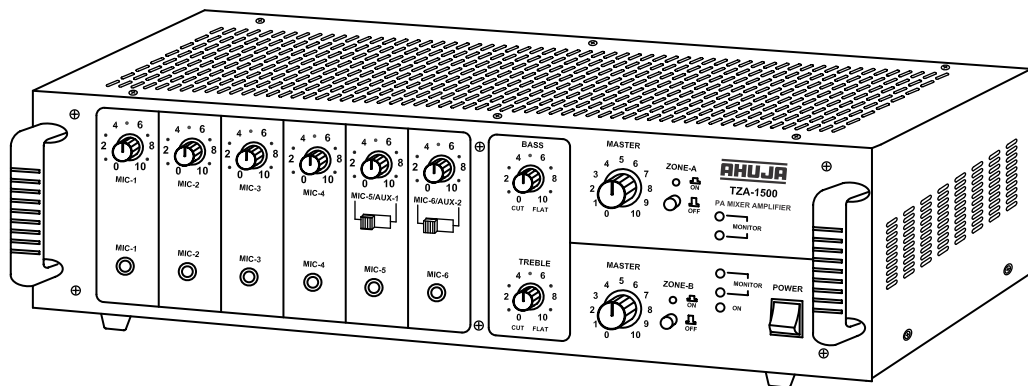

- ◆ Thank you for purchasing the AHUJA PA Mixer Amplifier.
- ◆ Please read this manual thoroughly before making connections and turning on the power. Following the instructions in this manual will enable you to obtain optimum performance from your new AHUJA PA Mixer Amplifier.
- ◆ Please retain this manual for future reference.

• Safety Instructions

Read the Instructions: Please read all the instructions in this section carefully before installation or use of the product. All the safety instructions must be followed.

Retain the Instructions: Please retain this Instruction Manual for future reference.



This symbol, wherever it appears, alerts you to the presence of uninsulated hazardous voltage that may be sufficient to constitute a risk of electric shock. External wiring to any terminal marked with this symbol must be done by a trained and instructed person only.



This symbol, wherever it appears adjacent to a component, alerts you that the concerned component can only be replaced by another of the exact same specifications.

WARNING

- To reduce the risk of electric shock, do not remove the top cover. No user serviceable parts inside. Refer all servicing to qualified personnel only.
- Before replacing any fuse, make sure the set is switched off and disconnected from the AC mains or any other power source. Replace a fuse only with another of exactly same specification.

CAUTIONS

Water & Moisture: To reduce the risk of fire or electrical shock, do not expose this set to rain or moisture. Do not use this set near water or in a wet location. Do not keep any object filled with liquid, such as a vase, on top of this set. Do not insert or remove the AC mains plug with wet hands.

Power Source: The voltage & frequency of the AC mains supply, and the voltage of the external battery, (if applicable) to which this set can be connected, is marked on the rear panel of the set. Do not connect this set to any power source other than those specified on the rear panel.

Power Cord Protection: Do not cut, kink, damage or modify the AC power cord supplied with this set. Keep the AC power cord away from heaters and harmful chemicals. Do not keep any heavy object on the power cord.

Operation on Generator: When operating this set on a generator, make sure the set is switched off till the generator voltage has stabilized.

Ventilation: This set should be situated so that its location or position does not interfere with its proper ventilation. Do not cover the ventilation holes / slots. Do not insert or drop anything into the ventilation holes / slots.

Stability: This set must be kept in a stable and flat horizontal position, and never in a tilted position. Do not place this set on an unstable stand, tripod, bracket or mount. Do not use attachments which are not supplied or explicitly recommended by the manufacturer.

Cover Strip: The cover strip of the 100V / 70V audio output terminal strip, and of any other high voltage output terminal strip, must be replaced after making connections. Failure to do so may result in exposure to hazardous voltages.

Earthing: This set must be earthed properly before use. A wire from the Earth terminal on the rear panel must be connected to electrical earth.

Cleaning: Disconnect this equipment from the AC mains and external battery before cleaning. Clean with a damp cloth, but do not allow any liquid to enter the set. Do not clean with liquids or aerosols.

Exposure to Heat: Do not touch the heatsinks while the set is working.

• Table of Contents

Contents	Page No.
• Features/General Description of Product	4
• Front Panel Controls & Features	5
• Rear Panel Controls & Features	6
• Interconnections	7
• Speaker Connection Guidelines	9
• Typical Applications	12
• Specifications	16

• Features/General Description of Product

- Ideal for use in a wide variety of 2- Zone PA applications where some loudspeakers are required to operate indoors and some outdoors at different volume levels with On/Off facility.
- TZA-1500® is a 160 Watts 2 zone amplifier offering 4 independent unbalanced Mic Inputs & 2 unbalanced Mic Inputs alternate to 2 Aux Inputs to feed one or both zone and with combined tone controls and individual master controls.
- Volume level of each zone can be adjusted independently to any desired level and can be switched On or Off without disturbing its volume level settings.
- Preamplifier Output is provided for connecting to a Booster Amplifier and for recording the programme.
- Power losses in speaker wirings are reduced as the Two zones share the delivering of 160W of power.
- Provision for automatic changeover from AC to battery operation ensuring continuity of program.
- Protection provided against the reverse polarity of battery connections.
- Ease of operation, combined with service accessibility has been optimized in the design.

• Front Panel Controls & Features

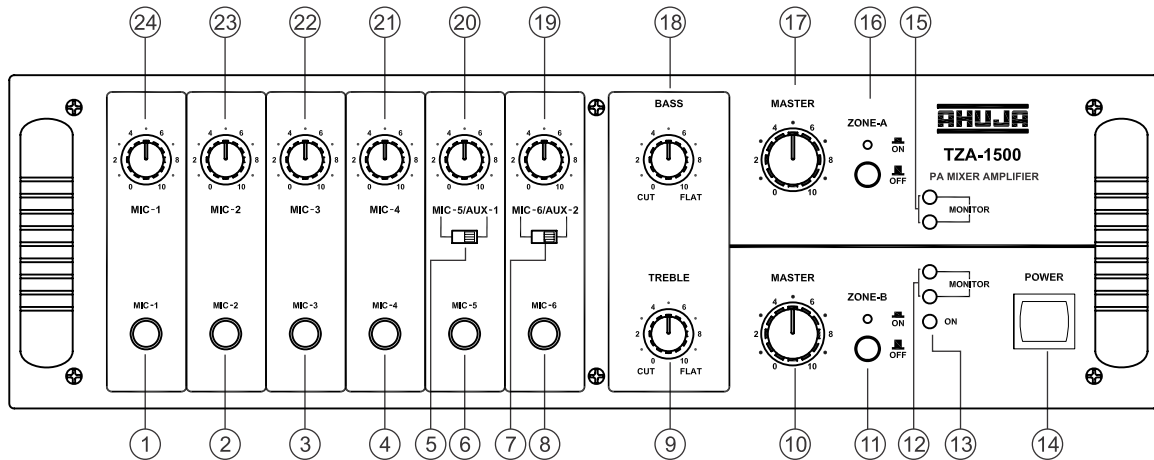

1. **MIC-1 Input Jack Socket**
For accepting unbalanced signal from a low impedance microphone.
2. **MIC-2 Input Jack Socket**
3. **MIC-3 Input Jack Socket**
4. **MIC-4 Input Jack Socket**
5. **MIC-5/AUX-1 Selector Switch**
6. **MIC-5 Input Jack Socket**
7. **MIC-6/AUX-2 Selector Switch**
8. **MIC-6 Input Jack Socket**
9. **TREBLE Control**
For cutting or boosting the signal level of high frequencies.
10. **MASTER Volume Control Zone-B**
For adjustment of the overall volume level of Zone-B.
11. **ZONE-B On/Off Switch**
12. **MONITOR LEDs Zone-B**
These indicate the output level of Zone-B.
13. **POWER LED**
This LED glows when the amplifier is switched ON.
14. **POWER Switch**
Push the top part of the knob to switch the amplifier ON. Push the bottom part of the knob to switch the amplifier OFF.
15. **MONITOR LEDs Zone-A**
These indicate the output level of Zone-A.
16. **ZONE-A On/Off Switch**
17. **MASTER Volume Control Zone-A**
For adjustment of the overall volume level of Zone-A.
18. **BASS Control**
For cutting or boosting the signal level of low frequencies.
19. **MIC-6/AUX-2 Volume Control**
20. **MIC-5/AUX-1 Volume Control**
21. **MIC-4 Volume Control**
22. **MIC-3 Volume Control**
23. **MIC-2 Volume Control**
24. **MIC-1 Volume Control**

• Rear Panel Controls & Features

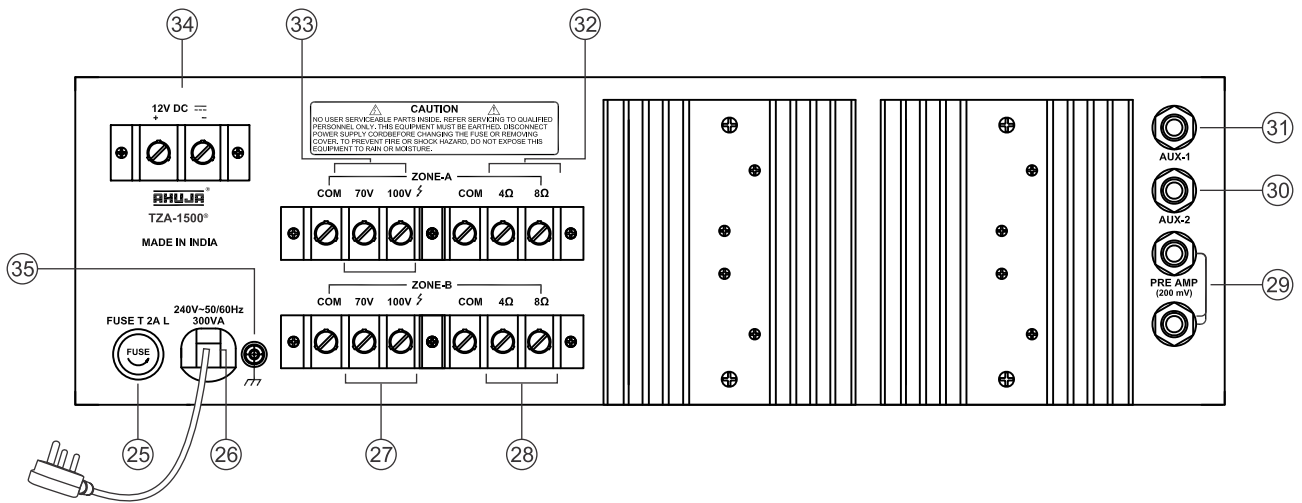

25. AC MAINS FUSE 2 AMP 250V (T 2A L)

This protects the amplifier from any excessive current flow.

26. 3 CORE AC MAINS CABLE With Plug

27. SPEAKER Terminal Block for Zone B (70V, 100V)

For connecting speakers with 100V line matching transformers.

28. SPEAKER Terminal Block for Zone B (4 ohm and 8 ohm)

For connecting low impedance speakers.

29. PREAMPLIFIER Output Jack Sockets

For connecting to the Aux input of another amplifier or a Recorder for recording purpose. Two jack have been provided in parallel.

30. AUX-2 Input Jack Socket

For accepting an unbalanced signal from an auxiliary source like a Tuner, Player, Echo or Audio Mixer etc.

31. AUX-1 Input Jack Socket

32. SPEAKER Terminal Block for Zone A (4 ohm and 8 ohm)

33. SPEAKER Terminal Block for Zone A (70V, 100V)

34. BATTERY Terminal Block

For connecting a 12V Car Battery as standby power source.

35. EARTH Terminal

• Interconnections

- The amplifier can be placed as a tabletop unit. Considerable heat is generated inside the amplifier during continuous use, therefore, the amplifier should be situated so that its location or position does not interfere with its proper ventilation.
- The amplifier must be powered through an AC earthed mains outlet.
- All connections must only be carried out or changed with the amplifier switched OFF.
- The amplifier may be operated from a DC supply of 12 Volts car battery.
- To avoid loud switching noise, always switch ON the amplifier after all other units of the audio system have been switched ON. After operation switch it OFF first and then the other units.
- The connection diagrams below, display the typical types of input sources (Mics, Keyboards, MP3 Players, Mixers, CD Players etc.) and speakers (Wall, Ceiling, Box, Horn, Column) which can be connected to the amplifier. For correct connection and operation check the specification of the connected equipment.

FRONT PANEL - TZA-1500®

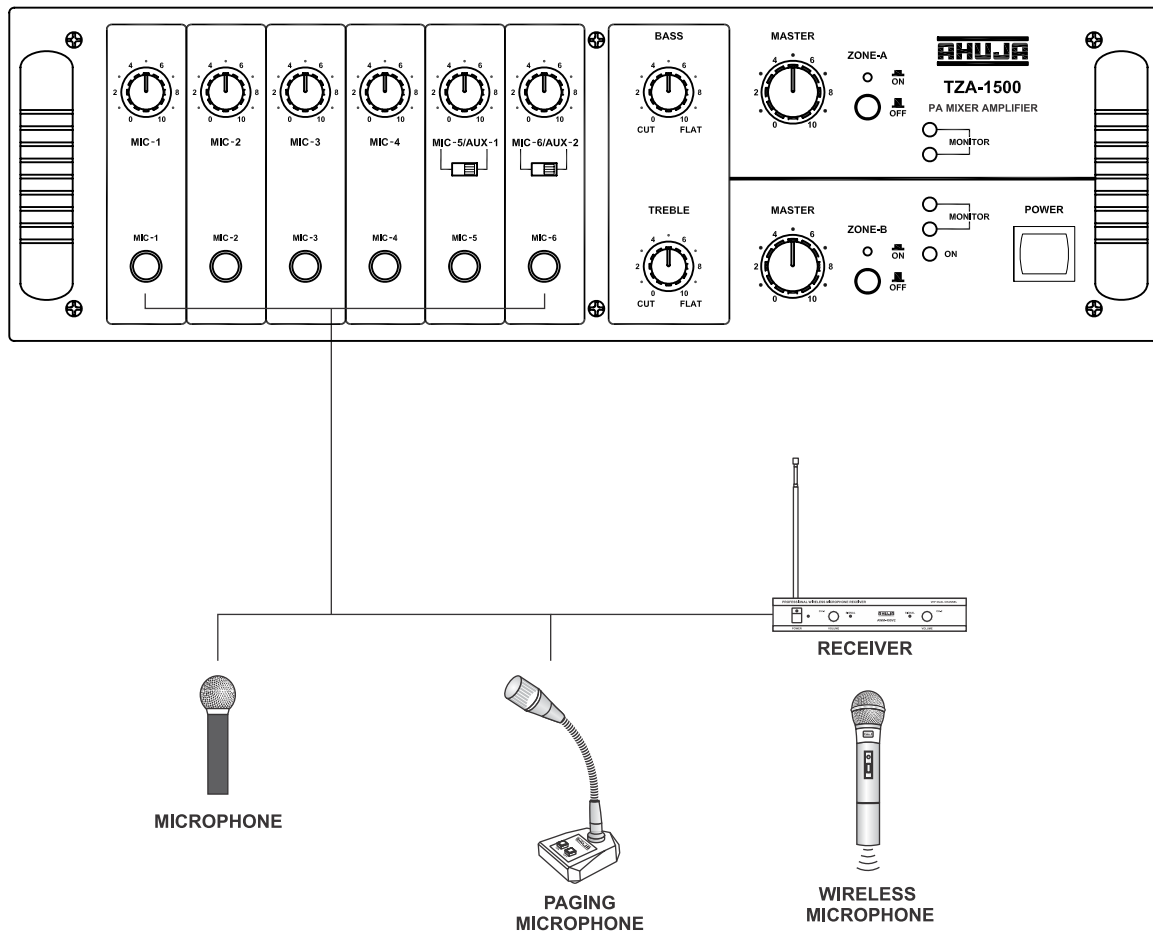

Interconnections....

REAR PANEL - TZA-1500®

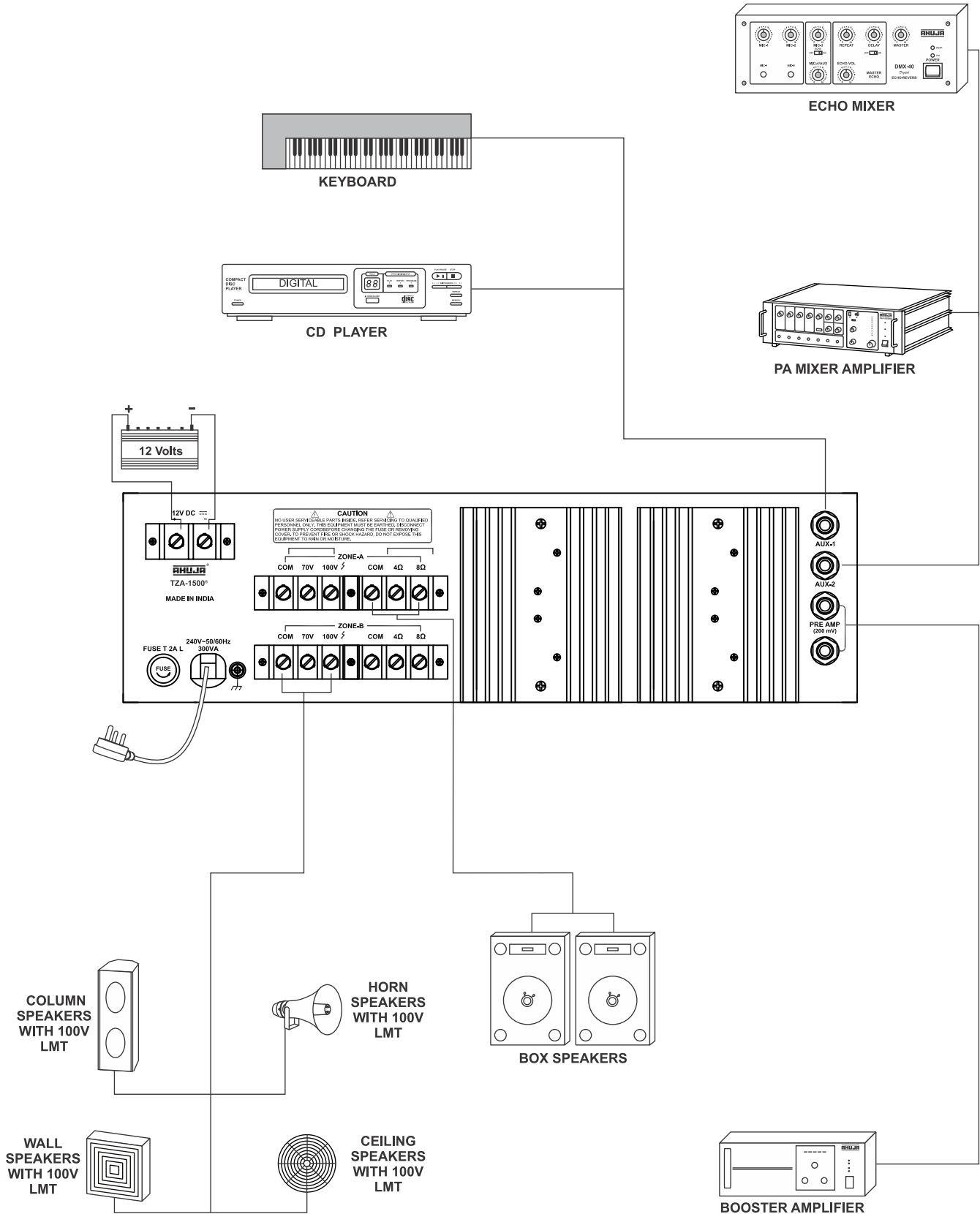

• Speaker Connection Guidelines

TZA-1500® is a medium power PA Mixer amplifier. Therefore it is very important that correct loudspeaker connections are made to avoid damage to the amplifier or speakers.

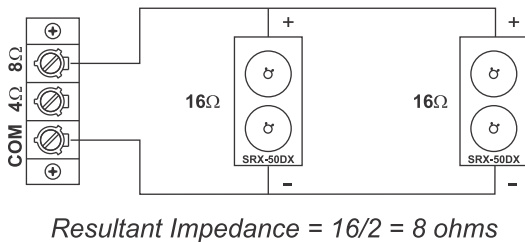
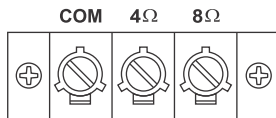

Resultant Impedance = $16/2 = 8$ ohms

Low Impedance Speaker Connections

- Box type Speakers can be directly connected to Com-4 ohm / 8 ohm Terminal Strip.
- No Driver Units / Horn Speakers / Column Speakers (with 100V LMT) should be connected to Com-4 ohm / 8 ohm

Connecting Two SRX-50DX Speakers on Each Zone

Two SRX-50DX Speakers (Each speaker can handle 50W of power) should be wired in parallel as shown in figure. The resulting impedance of the speaker system is 8 ohm. Thus they should be connected to the 8 ohm Tap of the amplifier.



Connecting One SRX-120DX Speaker on Each Zone

One SRX-120DX Speaker (Speaker can handle 100W of power) should be connected to 8 ohm tap on each zone as shown in figure.

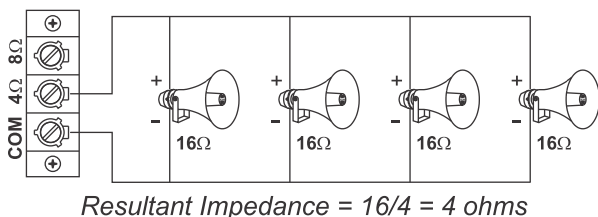

Resultant Impedance = $16/4 = 4$ ohms

Connecting Four Driver Units on Each Zone

Four Driver Units like AU-40 (40W) or AU-60 (60W) should be wired in parallel to each zone as shown in figure. The resulting impedance will be 4 ohm. The speaker system should be connected to the 4 ohm tap of each zone of the amplifier.

IMPORTANT

- When speakers are connected to COM-4 ohm / 8 ohm Terminal Strip NO speakers should be connected to the Red Terminal Strip marked COM-70V/100V of the same zone.
- Speakers should be connected only to either COM - 4 ohm or COM - 8 ohm terminals of the same zone as illustrated above but never to more than one set of terminals.

Speaker Connection Guidelines....

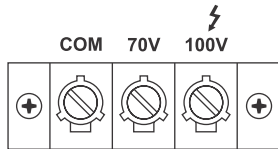

High Impedance Speakers or Speakers Using A 100V Line Matching Transformer

- Driver Units / Horn Speakers / Column Speakers with 100V Line Matching Transformers are only to be connected to Com-70V / 100V Terminal Strip.
- When any of the above speakers are connected to the Com-70V/100V Terminal Strip of a zone then No Box Speakers should be connected to the COM - 4 ohm - 8 ohm Terminal Strip of that zone.
- The power drawn from the amplifier should not exceed 80 Watts from each zone.

Connecting a combination of Driver Units and Columns Speakers with 100V LMTs on Zone A, Wall Speakers & Ceiling Speakers with 100V LMT on Zone B

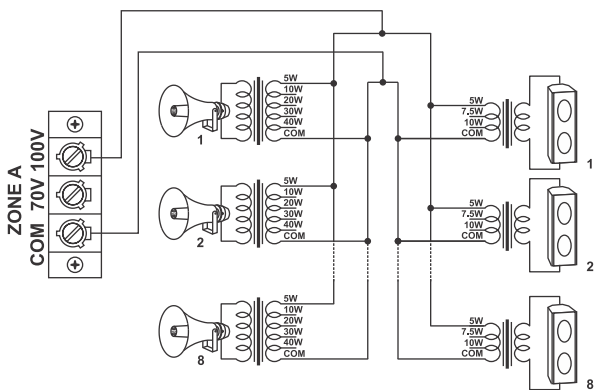

- 8 Driver Units with 100V LMTs connected at 5W and 8 Columns Speakers with 100V LMTs connected at 5W can be operated on Zone A.

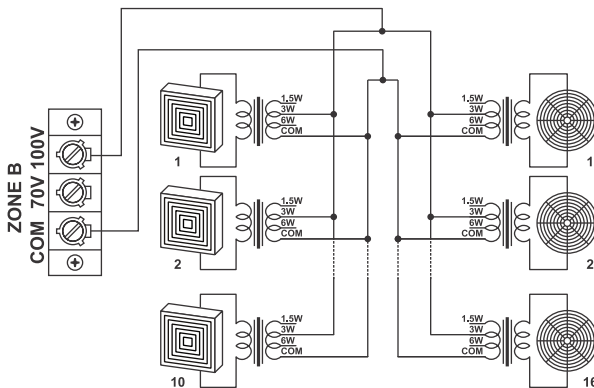

- 10 Wall Speakers with 100V LMT connected at 3W and 16 Ceiling Speakers with 100V LMT connected at 3W can be operated on Zone B.

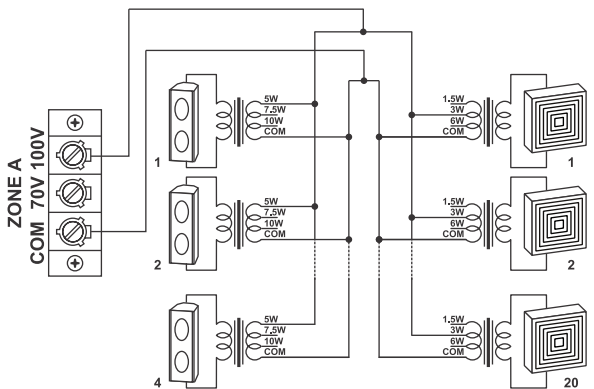

Connecting a combination of Column Speakers and Wall Speakers with 100V LMTs on Zone A, Horn Speaker with 100V LMT on Zone B

- 4 Column Speakers with 100V LMT connected at 5W tap and 20 Wall Speakers with 100V LMT connected at 3W can be operated on Zone A.

Speaker Connection Guidelines....

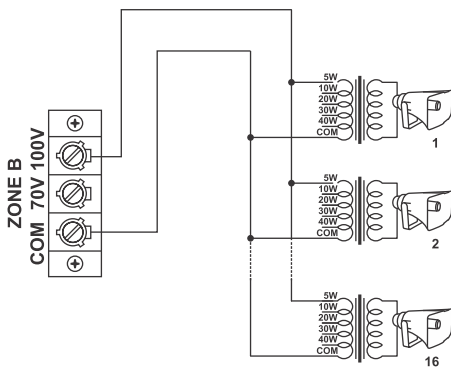

- On Zone B, 16 Horn Speakers with 100V LMT connected at 5W can be operated.

Use of 70 Volt Line

A loudspeaker / Driver Unit with its LMT adjusted to the 15W tap, when connected to COM and 100V terminals on the amplifier's Terminal Strip will draw 15W from the amplifier but when the same is connected to COM and 70V it will only draw half power or 7.5W. A good use of 70V line tap can be made in installations where large number of speakers / driver units are to be installed for more even distribution of sound.

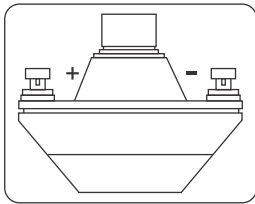

Correct Phasing of Loudspeakers

- When two or more Speakers/Units installed in the same area and are facing the same direction, it is essential that their cones/diaphragms act in unison. Otherwise the sound level of one speaker will be canceling the sound level of the other. To avoid any mistake, the terminals of Box speakers and the Driver Units are marked '+' & '-'. Always connect the COM of the Amplifier to '-' of speaker & 4/8 of the amplifier to the '+' of the speakers.
- In case of LMTs the COM of all the LMTs should be connected to the COM of the red strip terminal of the amplifier and the power tap to 100V line as shown in figure.

IMPORTANT

- When 70/100 Volt line is being used, no speakers / driver unit should be connected to 4 ohm / 8 ohm (Low Impedance) Tap of the same zone.
- Loudspeaker / driver unit should be connected to either COM-100V or COM-70V terminals, but never to more than one set of terminals.

Typical Applications

Connecting BR-250M On Each Zone To Make A 660W PA System

1. Connect the output of the CD Player to the Aux Input of TZA-1500® i.e., the source amplifier using a patch-cord with 1/4" phone plug on one end and two RCA plug on other end.
2. Connect the Pre-amp output from the TZA-1500® to the Input of first BR-250M, using a patch-cord with 1/4" phone plugs at both ends. Similarly connect Pre-amp output from TZA-1500® to the input of second BR-250M. Keep the Input Switch on BR-250M at 200mV sensitivity.
3. In this manner the CD Player will feed all the three amplifiers creating a 660W PA System.
4. Loudspeaker connections to the amplifiers should be done independently.
5. The left and right speaker stacks comprise of two sets of two SAX-200DXs and two SRX-120DXs. Two SAX-200DXs should be connected in parallel to each BR-250M and one SRX-120DX should be connected to each zone of the TZA-1500®.
6. Speaker system impedance should be matched to the output impedance of the amplifier and thus should be connected to the corresponding tap of the amplifier.
7. The Box Speaker / Driver Unit selector switch on both BR-250M should be set to the Box Speaker side.
8. Finally when operating the system, the Bass and Treble controls of the TZA-1500® should be set to flat and any adjustments in the tonal quality of the sound should be adjusted as per requirement.

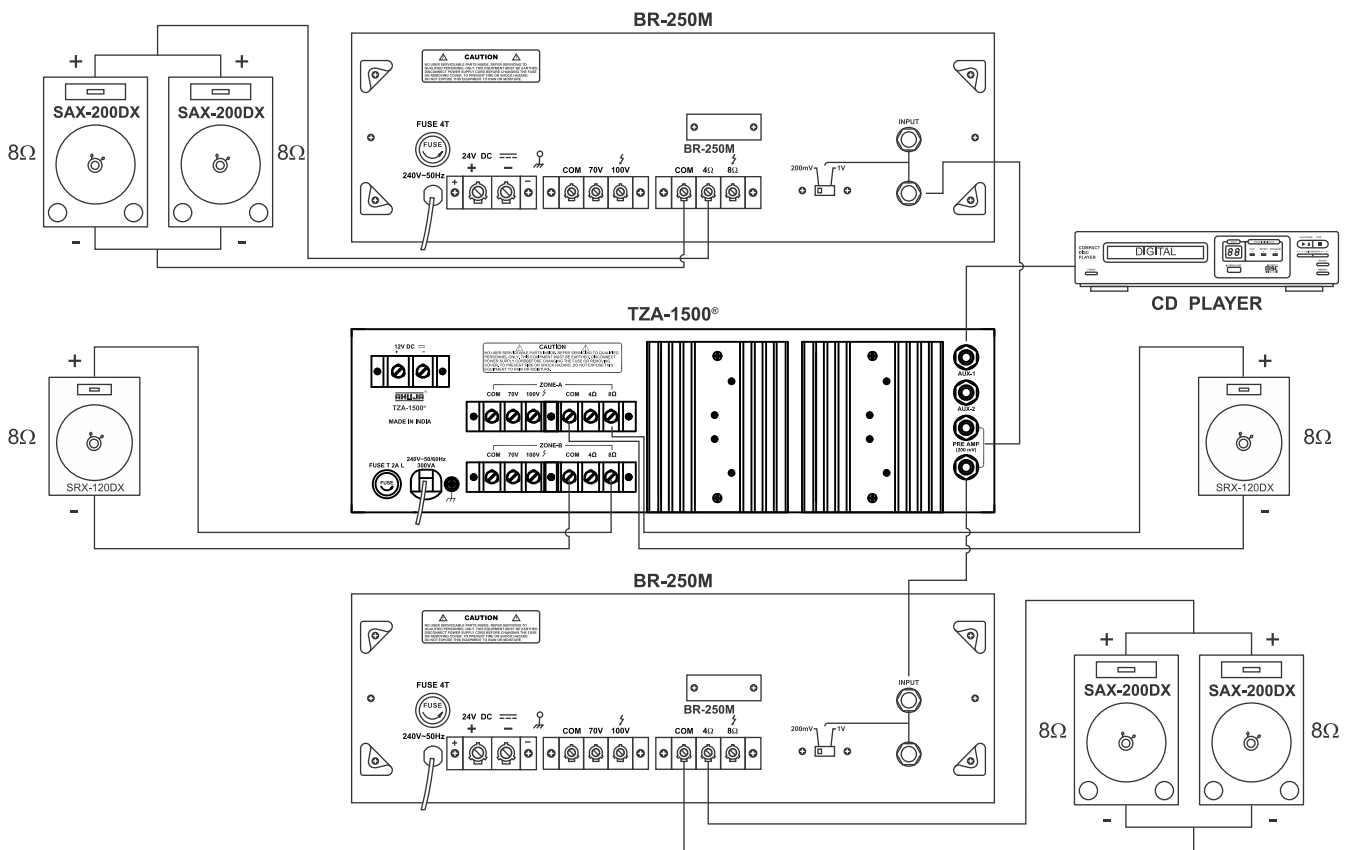

Connecting Similar/Different Types of Speakers for Indoor and Outdoor applications

1. In places where box type speakers are to be used for inside the hall and driver units with 100V line matching transformer are to be installed for the outside.
2. Here box type speakers are connected on one zone and driver units are connected on the other zone.
3. The volume of both the zones can be adjusted with the help of respective Master Controls. The box speakers are to be operated on low volume inside the hall. The driver units are to be operated on a higher volume level of the outside.
4. The tonal quality can be adjusted by Bass and Treble Controls.

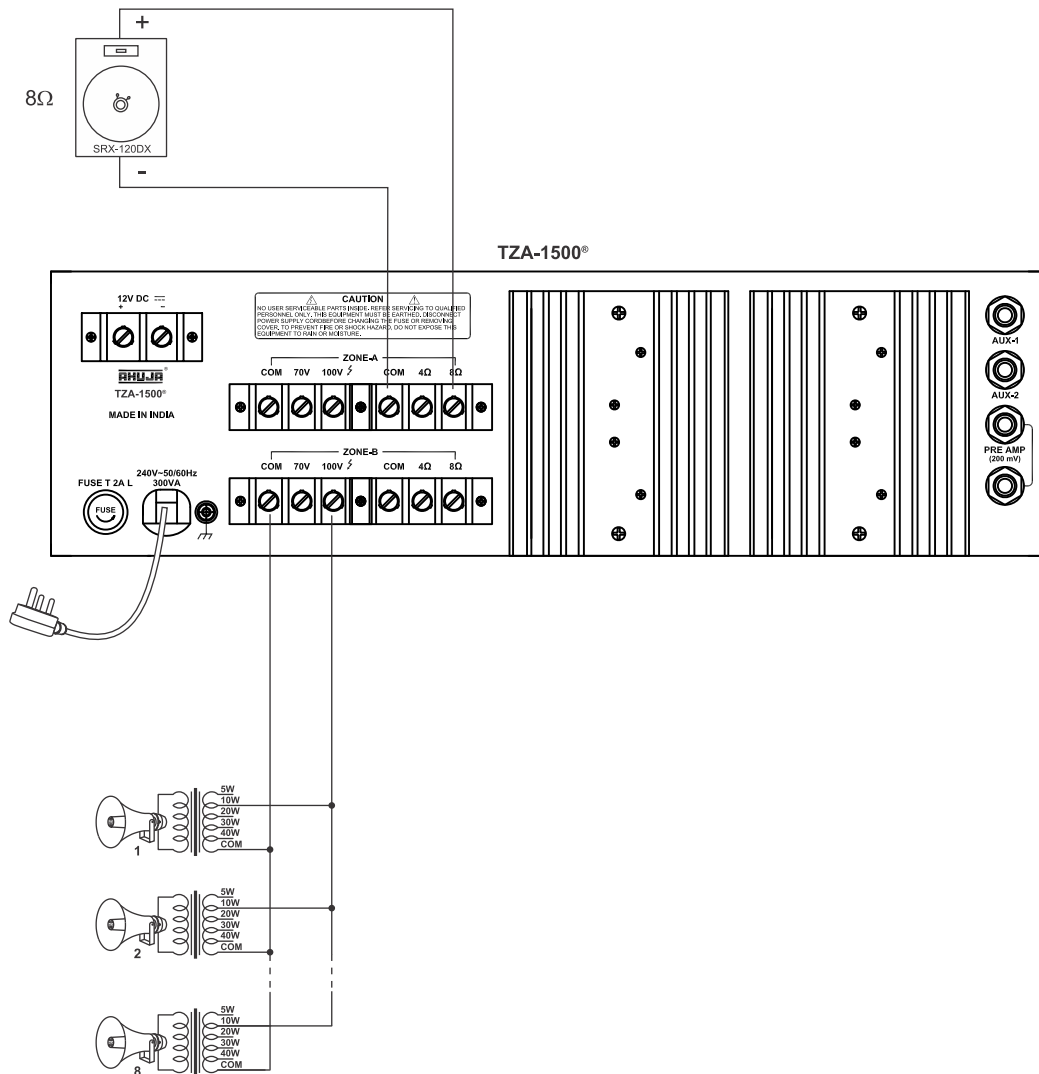

Typical Applications....

Connecting SPA-5000EM On Each Zone To Make A 1160W PA System

1. Connect the output of the CD Player to the Aux Input of TZA-1500® i.e., the source amplifier using a patch-cord with 1/4" phone plug on one end and two RCA plug on other end.
2. Connect the Pre-amp output from TZA-1500® to the Input of first SPA-5000EM, using a patch-cord with 1/4" phone plugs at both ends. Similarly connect Pre-amp output from TZA-1500® to the input of second SPA-5000EM. Keep the Input Switch on SPA-5000EM at 200mV sensitivity.
3. In this manner the CD Player will feed all the three amplifiers creating a 1160W PA System.
4. Loudspeaker connections to the amplifiers should be done independently.
5. The left and right speaker stacks comprise of two sets of two SAX-300DXs and two SRX-120DXs. Two SAX-300DXs should be connected in parallel to each SPA-5000EM and one SRX-120DX should be connected to each zone of the TZA-1500®.
6. Speaker system impedance should be matched to the output impedance of the amplifier and thus should be connected to the corresponding tap of the amplifier.
7. The Box Speaker / Driver Unit selector switch on both SPA-5000EM should be set to the Box Speaker side.
8. Finally when operating the system, the Bass and Treble controls of the TZA-1500® should be set to flat and any adjustments in the tonal quality of the sound should be adjusted as per requirement.

(Refer to page 15 for illustration)

Connecting SPA-5000EM On Each Zone To Make A 1160W PA System

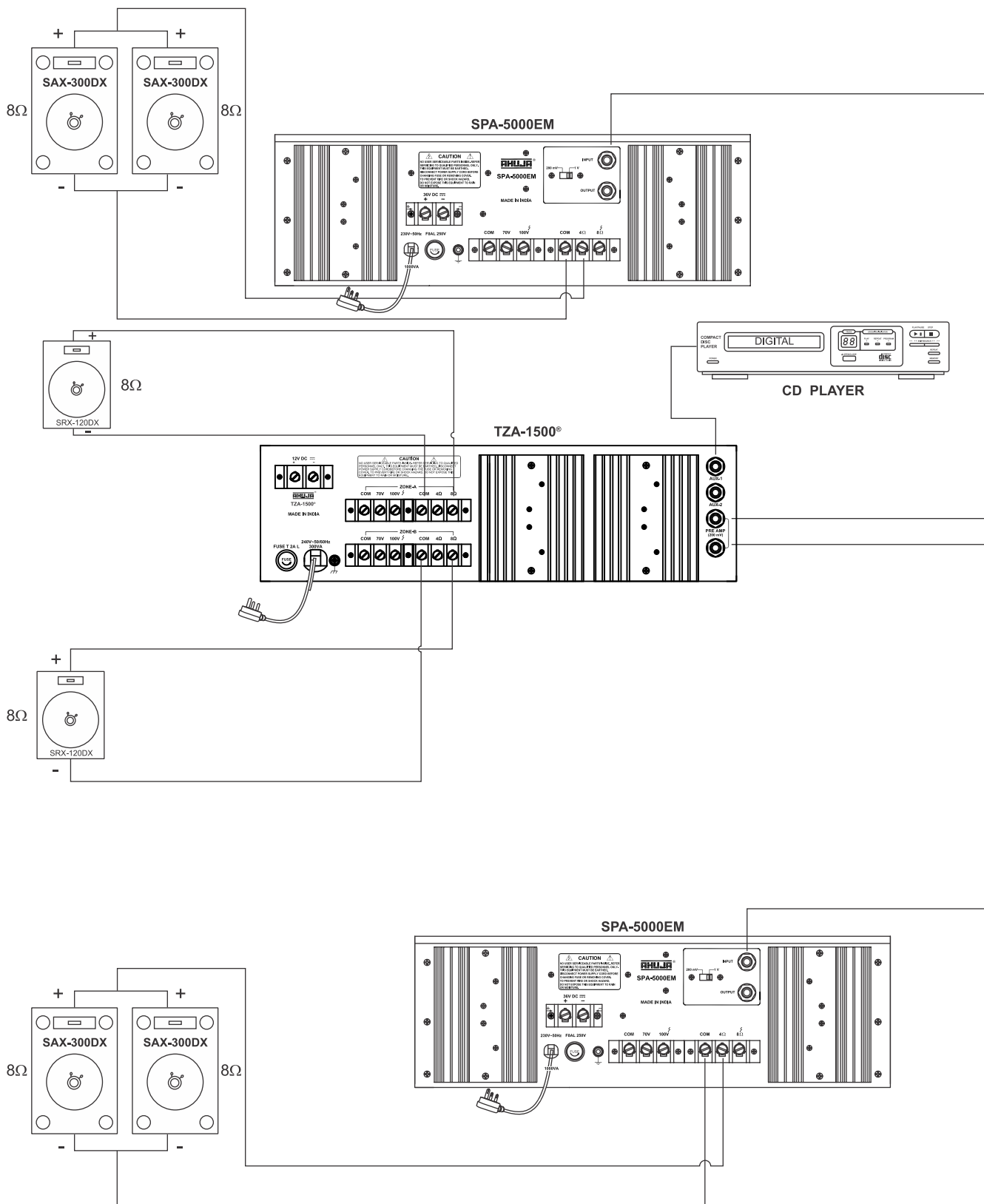

• Specifications

Model TZA-1500®	ZONE-A	ZONE-B
Power Output	100W RMS Max. 80W RMS at 10% THD 70W RMS at 5% THD 60W RMS at 2% THD	100W RMS Max. 80W RMS at 10% THD 70W RMS at 5% THD 60W RMS at 2% THD
Output Regulation	≤2 dB no load to full load at 1kHz	
Input Channels	Mic (1-6) 0.6mV / 4.7kΩ (Mic Source Imp. 50Ω to 1kΩ) Aux 1 & 2 : 100mV / 470kΩ	
Frequency Response	65Hz – 15,000 Hz ±3dB	65Hz – 15,000Hz ±3dB
S/N Ratio	60dB	60dB
Tone Controls	Bass: -10dB at 100Hz	Bass: -10dB at 100Hz
	Treble: -10dB at 10kHz	Treble: -10dB at 10kHz
Preamp Output	200mV / 600Ω	
Output Taps for Speaker Matching	4 & 8Ω (for direct connections) 70 & 100V Line (for use with LMT)	4 & 8Ω (for direct connections) 70 & 100V Line (for use with LMT)
Power Supply	AC: 220-240V 50/60Hz; DC: 12V (1×12V Car Battery)	
Protection	AC: Fuse 2Amp. (T 2A L); DC: Fuse 2×10Amp. (Both Zone) (T 10A L)	
AC Power Consumption	300VA	
DC Power Consumption	3A	3A
Dimensions	W460 x H155 x D310 mm	
Net Weight	14.20 kg (approx.)	

- Design and Specifications are subject to change without notice owing to continuous product up-gradation.
- Technical specifications are subject to production tolerances.

AHUJA RADIOS

215, Okhla Industrial Estate, New Delhi-110020, INDIA
C-45, Phase-II, Noida-201305 (UP) INDIA
Tel.: +91-11-26831549, 41612474 Fax: +91-11-26847287
E-mail: ahuja@ahujaradios.com Website: www.ahujaradios.com

- Design and Specifications are subject to change without notice owing to continuous product up-gradation
- Technical specifications are subject to production tolerances.
- We cannot be held responsible for printing errors, should they occur.
- AHUJA is a registered trademark of Ahuja Radios in India and other countries.
- © Copyright Ahuja Radios, 2013. All rights reserved. Any unauthorized reproduction or use of logos, images or design elements is strictly prohibited by law.
- No part of this compilation may be reproduced in any manner or translated without written permission.

